







# Production Drilling Assembly Tools



**REAL TOOLS FOR REAL WORK.™**



# Contents

## Air Production Drills

-  **4**  
Pistol Grip Drills
-  **11**  
Inline Drills
-  **14**  
Angle Drills
-  **19**  
Modular Drills
-  **21**  
Feed Drills





## Accessories

-  **67, 68**  
Spindle Accessories
-  **69**  
Other Accessories



## Other Air Tools

-  **64**  
Air Tappers
-  **66**  
Electro Dressers



### 5, 6 & 7 Series Air Angle Drills

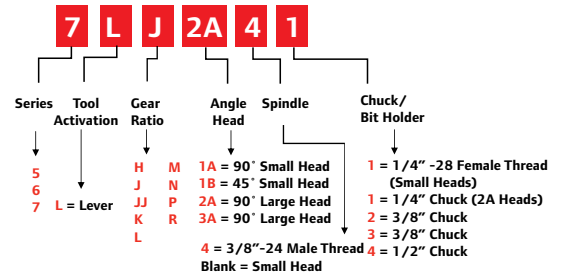

# Model Identification Guide

### Q2 Series Air Drills

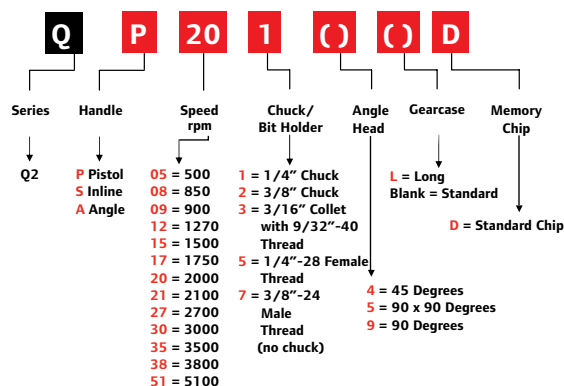

### 728 Series Air Pistol Drills

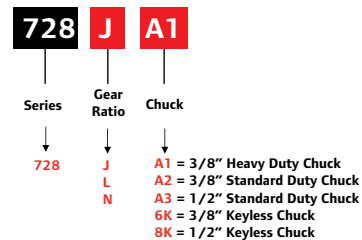



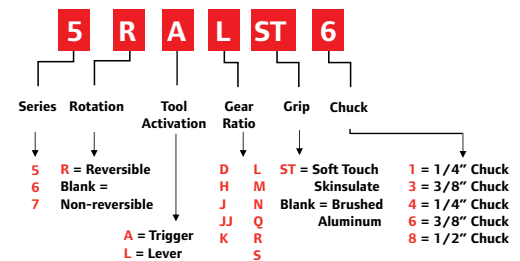













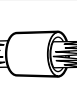

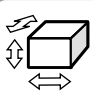

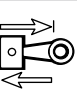







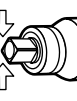



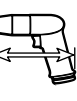

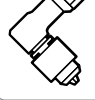
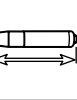



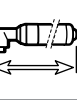

### 5, 6 & 7 Series Air Inline & Pistol Drills

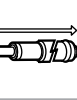
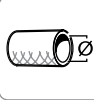

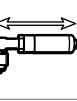
# Technical Symbols

For ease of use, specification tables frequently use symbols in column headings. Please reference the chart below for exact descriptions.

 Voltage	 Max chuck/collet capacity or bit holder	 Side-to-center distance	 Spindle length
 Spindle accessories	 Tool weight	 Side-to-center distance	 Spindle length
 Drilling	 Max. air consumption	 Side-to-center distance	 Size
 Tapping	 Piston stroke	 Side-to-center distance	 Bore
 Riveting	 Spindle thread	 Side-to-center distance	 Electrode dressers
 Pistol grip drills	 Square drive or bit holder	 Angle head height	 Working stations
 Straight drills	 Tool length	 Nominal load capacity	 Other accessories
 Angle drills	 Tool length	 Sound level	 Parts manual
 Reversible models	 Tool length	 Tool air inlet connection	 Product information manual
 Non-reversible models	 Tool length	 Hose min. internal diameter	 Maintenance information manual
 Max. free speed	 Tool length	 Rated power	 Operation and maintenance manual
 Stall torque			

# Air Production Drills

## Pistol Grip

### Q2 Series



Compact and light weight, Q2 drills deliver more power in a smaller package to get the job done in less time.

#### Features

- Stall torque: 9.7 – 86.4 in-lbs (1.1 – 9.8 Nm)
- Speeds: 500 – 5100 rpm
- Compact and lightweight, this tool delivers more power in a smaller package to get the job done in less time
- Variable speed control allows slow starting and high speed for fast drilling
- Ergonomic design reduces operator fatigue
- Excellent power-to-weight ratio gets the job done with less fatigue

#### Service and Accessories

##### Manuals:

-  16572745
-  16572034
-  16572679

##### Accessories:







- Horizontal hanger: 3RA-365
- Chuck: R0H-99
- Spindle accessories



##### Kits:

- Tune-up kit: Q2-PDRILL-TK1



QP151D

Model	 Max. Nm in-lbs (Nm)	 1 min. rpm	 lbs (kg)	 in (mm)	 Max. in (mm)	 in (mm)	 cfm (L/Min)
<b>DC TRIGGER START</b>							
QP511LD	9.7 (1.1)	5,100	1.4 (0.7)	6.7" (171)	1/4" (6)	0.6" (15)	16 (450)
QP381D	13.3 (1.5)	3,800	1.5 (0.7)	7.2" (184)	1/4" (6)	0.6" (15)	16 (450)
QP301LD	15.9 (1.8)	3,000	1.4 (0.7)	6.7" (171)	1/4" (6)	0.6" (15)	16 (450)
QP302LD	15.9 (1.8)	3,000	1.7 (0.8)	6.7" (171)	3/8" (10)	0.7" (18)	16 (450)
QP201D	24.8 (2.8)	2,000	1.5 (0.7)	7.2" (184)	1/4" (6)	0.6" (15)	16 (450)
QP202D	24.8 (2.8)	2,000	1.8 (0.8)	7.2" (184)	3/8" (10)	0.7" (18)	16 (450)
QP151D	30.1 (3.4)	1,500	1.5 (0.7)	7.2" (184)	1/4" (6)	0.6" (15)	16 (450)
QP152D	30.1 (3.4)	1,500	1.8 (0.8)	7.2" (184)	3/8" (10)	0.7" (18)	16 (450)
QP091D	51.3 (5.8)	900	1.5 (0.7)	7.2" (184)	1/4" (6)	0.6" (15)	16 (450)
QP051D	86.4 (9.8)	500	1.5 (0.7)	7.2" (184)	1/4" (6)	0.6" (15)	16 (450)
QP052D	86.4 (9.8)	500	1.8 (0.8)	7.2" (184)	3/8" (10)	0.7 (18)	16 (450)

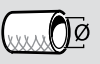
Series				
Q2	0.25 hp	75 dBa	1/4" NPT	1/4" (6 mm)

# Air Production Drills

## Pistol Grip

### 5 Series

Durability and performance are the hallmarks of these proven winners.

#### Features

- Stall Torque: 20 – 79.7 in-lbs (2.3 – 9.0 Nm)
- Speeds: 900 – 2000 rpm
- Variable speed control allows slow starting and high speed for fast drilling
- Skinsulate housing for operator comfort and productivity
- Excellent power-to-weight ratio gets the job done with less fatigue



5RANST8

#### Service and Accessories

##### Manuals:

P7092

##### Accessories:

Piped away exhaust kit: 5L-K184  
 Horizontal hanger: 5RA-A365  
 Chuck: 6A-99  
 Dead handle: 728N-A48, (requires 2): 5A-49

##### Kits:

Tune-up kit: 5RA/5RL-TK1

Model	in-lbs (Nm)	rpm	lbs (kg)	in (mm)	in (mm)	in (mm)	cfm (L/Min)
<b>DC TRIGGER START</b>							
5RALST6	35.4 (4.0)	2,000	2.2 (1.0)	6.2" (157)	3/8" (10)	0.8" (21)	17 (480)
5RANST8	70.8 (8.0)	900	3.0 (1.4)	8.3" (210)	1/2" (13)	0.8" (21)	17 (480)
5RANST6	70.8 (8.0)	900	3.0 (1.4)	8.3" (210)	3/8" (10)	0.8" (21)	17 (480)
<b>C TRIGGER START</b>							
5AHST4	20 (2.3)	5,000	2.0 (0.9)	6.8" (173)	1/4" (6)	0.8" (21)	17 (480)
5AJST4	20 (2.3)	4,500	2.0 (0.9)	6.8" (173)	1/4" (6)	0.8" (21)	17 (480)
5AKST4	30.1 (3.4)	3,000	2.0 (0.9)	6.8" (173)	1/4" (6)	0.8" (21)	17 (480)
5ALST4	39.8 (4.5)	2,200	2.0 (0.9)	6.8" (173)	1/4" (6)	0.8" (21)	17 (480)
5ANST6	79.7 (9.0)	1,000	2.8 (1.3)	8.1" (207)	3/8" (10)	0.8" (21)	17 (480)

Series				
5	0.40 hp	75 dBA	1/4" NPT	1/4" (6 mm)

# Air Production Drills

## Pistol Grip

### 6 Series

Dependability and consistency have made the 6 series drills a staple in many assembly environments.

#### Features

- Stall Torque: 7.1 – 316 in-lbs (0.8 – 35.7 Nm)
- Speeds: 350 – 20,000 rpm
- Skinsulate housing for operator comfort and productivity
- Cantilever-mounted planetary gears are easily accessible without need to press from gear frame; simplifies maintenance
- Excellent power-to-weight ratio gets the job done with less fatigue



6ALST4

#### Service and Accessories

##### Manuals:

- 16572828
- 16572190
- 16572604

##### Accessories:

- Horizontal hanger: 6WS-366
- Vertical hanger: 7L-365
- Dead handle: R1A-A48, (requires 2): 6A-49
- Chuck: R00A-99

##### Kits:

- Tune-up kit: 6-DRILLS-TK1

Model	in-lbs (Nm)	rpm	lbs (kg)	in (mm)	in (mm)	in (mm)	cfm (L/Min)
<b>C TRIGGER START</b>							
6ADST4	7.1 (0.8)	20,000	2.2 (1.0)	7.0" (178)	1/4" (6)	0.8" (21)	20 (560)
6AHST4	23 (2.6)	6,000	2.2 (1.0)	7.0" (178)	1/4" (6)	0.8" (21)	20 (560)
6AJST4	27 (3.1)	5,100	2.2 (1.0)	7.0" (178)	1/4" (6)	0.8" (21)	20 (560)
6AJJST4	35 (4.1)	3,950	2.2 (1.0)	7.0" (178)	1/4" (6)	0.8" (21)	20 (560)
6AKST4	45.1 (5.1)	3,100	2.2 (1.0)	7.0" (178)	1/4" (6)	0.8" (21)	20 (560)
6ALST4	64.6 (7.3)	2,150	2.2 (1.0)	7.0" (178)	1/4" (6)	0.8" (21)	20 (560)
6AMST6	89.4 (10.1)	1,500	2.8 (1.3)	8.0" (203)	3/8" (10)	0.8" (21)	20 (560)
6ARST6	222.2 (25.1)	500	3.0 (1.4)	8.3" (210)	3/8" (10)	0.8" (21)	20 (560)
6ASST6	316 (35.7)	350	3.0 (1.4)	8.3" (210)	3/8" (10)	0.8" (21)	20 (560)

Series				
6	0.51 hp	74 dBa	1/4" NPT	3/8" (10 mm)

# Air Production Drills

## Pistol Grip

### 7 Series

Durability and performance are the hallmarks of these proven winners.

#### Features

- Stall Torque: 10 – 270 in-lbs (1.13 – 30.5 Nm)
- Speeds: 600 – 20,000 rpm
- Skinsulate housing for operator comfort and productivity
- Cantilever-mounted planetary gears are easily accessible without need to press from gear frame; simplifies maintenance
- Excellent power-to-weight ratio gets the job done with less fatigue



7AQST8

#### Service and Accessories

##### Manuals:

P7094

##### Accessories:

Horizontal hanger: 7RA-A366  
 Dead handle: R1A-48, (requires 2): 7A-49  
 Chuck: ROK-99

##### Kits:

Tune-up kit: 7A-DRILLS-TK1

Model	in-lbs (Nm)	rpm	lbs (kg)	in (mm)	<i>Max.</i> in (mm)	in (mm)	cfm (L/Min)
<b>C TRIGGER START</b>							
7ADST4	10 (1.1)	20,000	2.2 (1.0)	7.4" (189)	1/4" (6)	0.9" (22)	25 (700)
7AHST4	33 (3.7)	6,000	2.3 (1.1)	7.4" (189)	1/4" (6)	0.9" (22)	25 (700)
7AJST4	40 (4.5)	4,800	2.3 (1.1)	7.4" (189)	1/4" (6)	0.9" (22)	25 (700)
7AJJST4	47 (5.5)	4,000	2.3 (1.1)	7.4" (189)	1/4" (6)	0.9" (22)	25 (700)
7AKST6	58 (6.6)	3,200	2.4 (1.1)	7.6" (194)	3/8" (10)	0.9" (22)	25 (700)
7ALST6	78 (8.8)	2,400	2.7 (1.2)	7.8" (198)	3/8" (10)	0.9" (22)	25 (700)
7AMST6	130.1 (14.7)	1,400	2.9 (1.3)	8.5" (216)	3/8" (10)	0.9" (22)	25 (700)
7ANST8	185.0 (20.9)	900	3.2 (1.5)	8.7" (222)	1/2" (13)	0.9" (22)	25 (700)
7AQST8	269.9 (30.5)	600	3.2 (1.5)	8.7" (222)	1/2" (13)	0.9" (22)	25 (700)

Series				
7	0.75 hp	82 dBa	1/4" NPT	5/16" (8 mm)

# Air Production Drills

## Pistol Grip

### 7800 Series

The 7800 series drills offer enough power for your toughest applications.

#### Features

- Stall Torque: 48 – 654 in-lbs (5.4 – 74 Nm)
- Speeds: 350 – 4500 rpm
- Excellent for production-line drilling of large diameter holes
- Double row ball bearing construction assures max TIR of .005" for precise, concentric holes
- Side handle on 350/600 rpm models

#### Service and Accessories

##### Manuals:

49999011

##### Accessories:

Spindle accessories  
Swivel air inlet



Model	in-lbs (Nm)	rpm	lbs (kg)	in (mm)	in (mm)	in (mm)	cfm (L/Min)
<b>TRIGGER START</b>							
7845-E	48 (5.4)	4,500	3.9 (1.8)	8.3" (210)	3/8" (10)	1.0" (25)	31 (840)
7846-E	90 (10)	2,400	3.9 (1.8)	8.3" (210)	3/8" (10)	1.0" (25)	31 (840)
7847-E	192 (22)	1,100	5.4 (2.4)	10.5" (267)	1/2" (13)	1.0" (25)	31 (840)
7848-E	354 (40)	600	5.4 (2.4)	10.5" (267)	1/2" (13)	1.0" (25)	31 (840)
7849-E	654 (74)	350	5.4 (2.4)	10.5" (267)	1/2" (13)	1.0" (25)	31 (840)

Series	0.70 hp	88 dBa	1/4" NPT	5/16" (8 mm)
7800	0.70 hp	88 dBa	1/4" NPT	5/16" (8 mm)

#### IQ<sup>V20</sup> Series™ Impactool™

Model	Battery	Voltage DC	Drive Size, Type
W7150	BL2010	20	1/2" Square
W7250	BL2010	20	1/2", 2" Square



# Air Production Drills

## Pistol Grip

### 8500 Series

Unique Quick Reverse Touch (QRT) control trigger makes this design well-adapted to applications requiring frequent reversing.

#### Features

- Stall Torque: 960 – 1320 in-lbs (9.1 – 12.5 Nm)
- Speeds: 600 – 900 rpm
- High and low speed model options

#### Service and Accessories

##### Manuals:

 49999032

##### Accessories:







Spindle accessories  
Swivel air inlet





##### Kits:

Service kit: 42122-2



8506-ADB

Model	 in-lbs (Nm)	 rpm	 lbs (kg)	 in (mm)	 in (mm)	 in (mm)	 cfm (L/Min)
<b>C TRIGGER START</b>							
8509-ADB	80 (9.1)	900	2.9" (1.3)	8.0" (203)	3/8" (10)	0.9" (23)	24 (678)
8509-ADK	80 (9.1)	900	2.9" (1.3)	8.0" (203)	1/2" (13)	0.9" (23)	24 (678)
8506-ADB	110 (12.5)	600	2.9" (1.3)	8.0" (203)	3/8" (10)	0.9" (23)	26 (732)
8506-ADK	110 (12.5)	600	2.9" (1.3)	8.0" (203)	1/2" (13)	0.9" (23)	26 (732)

Series				
8500	0.31 hp	82 dBa	1/4" NPT	5/16" (8 mm)

	Impacts per Minute	No-Load Speed rpm	Nut-Busting Torque ft-lb (Nm)	Max. Torque ft-lb (Nm)	Tool & Battery Weight lb (kg)	Length in (mm)
e	2,300	0–1,900	1,100 (1,491)	780 (1,057)	6.8 (3.1)	9.4 (238)
xtension	2,300	0–1,900	1,100 (1,491)	780 (1,057)	6.9 (3.1)	11.2 (285)

# Air Maintenance Drills

## Pistol Grip

### 728 Series

728 Series drills are economical general purpose drills ideal for most maintenance applications.

#### Features

- Stall Torque: 30 – 120 in-lbs (3.4 – 13.6 Nm)
- Speeds: 950 – 3800 rpm
- Power: 0.50 hp
- Keyed and keyless chuck sizes: 5/16" – 1/2"
- Dead handle standard on 728NA3
- Economically priced for general maintenance applications

#### Service and Accessories

##### Manuals:

 P6297

##### Accessories:







Spindle accessories  
Swivel air inlet,

##### Kits:

Tune-up kit: 728-TK3



728L6K

Model	 <b>Max. Nm</b> in-lbs (Nm)	 <b>1 min. rpm</b> rpm	 <b>lbs (kg)</b>	 <b>in (mm)</b>	<b>Max.</b>  <b>in (mm)</b>	 <b>in (mm)</b>	 <b>cfm (L/Min)</b>
<b>TRIGGER START</b>							
728JA1	30 (3.4)	3,800	2.4 (1.1)	7.0" (177)	3/8" (10)	0.9" (23)	19 (538)
728J6K	30 (3.4)	3,800	2.4 (1.1)	7.0" (177)	3/8" (10)*	0.9" (23)	19 (538)
728LA2	54 (6.1)	2,100	2.5 (1.2)	7.3" (184)	3/8" (10)	0.9" (23)	19 (538)
728L6K	54 (6.1)	2,100	2.5 (1.2)	7.3" (184)	3/8" (10)*	0.9" (23)	19 (538)
728NA3	120 (14)	950	3.1 (1.4)	8.4" (212)	1/2" (13)	0.9" (23)	19 (538)
728N8K	120 (14)	950	3.1 (1.4)	8.4" (212)	1/2" (13)*	0.9" (23)	19 (538)

\*Keyless chuck.

Series			
Maintenance Drills	84 dBa	1/4" NPT	1/4" (6 mm)

# Air Production Drills

Inline

## Q2 Series



Compact and lightweight, Q2 drills deliver more power in a smaller package to get the job done in less time.

### Features

- Stall Torque: 10.6 – 33.6 in-lbs (1.2 – 3.8 Nm)
- Speeds: 1500 – 5100 rpm
- Variable speed control allows slow starting and high speed for fast drilling
- Excellent power-to-weight ratio gets the job done with less fatigue

### Service and Accessories

#### Manuals:

-  16572752
-  16572042
-  16576332

#### Accessories:







- Horizontal hanger: 3RA-365
- Chuck: ROH-99
- Spindle accessories

#### Kits:

- Tune-up kit: Q2-PDRILL-TK1



Q5151D

Model	 in-lbs (Nm)	 rpm	 lbs (kg)	 in (mm)	 in (mm)	 in (mm)	 cfm (L/Min)
<b>C LEVER START</b>							
QS11D	10.6 (1.2)	5,100	1.4 (0.6)	8.1" (205)	1/4" (6)	0.6" (15)	16 (450)
QS381D	13.3 (1.5)	3,800	1.4 (0.6)	8.1" (205)	1/4" (6)	0.6" (15)	16 (450)
QS301D	16.8 (1.9)	3,000	1.4 (0.6)	8.1" (205)	1/4" (6)	0.6" (15)	16 (450)
Q5151D	33.6 (3.8)	1,500	1.4 (0.6)	8.1" (205)	1/4" (6)	0.6" (15)	16 (450)

Series					
Q2	0.30 hp	75 dBa	1/4" NPT	1/4" (6 mm)	3/8"-24

# Air Production Drills

## Inline

### 5 & 6 Series

Dependability and consistency makes the 5 and 6 Series drills a staple in many assembly environments.



6LJ1

#### Features

- Stall Torque: 20.4 – 222.2 in-lbs (2.3 – 25.1 Nm)
- Speeds: 500 – 6,000 rpm
- Variable speed control allows slow starting and high speed for fast drilling
- Cantilever-mounted planetary gears are easily accessible without need to press from gear frame; simplifies maintenance
- Excellent power-to-weight ratio gets the job done with less fatigue

#### Service and Accessories

##### Manuals:

- 16572786 5 Series
- 16572828 6 Series

##### 5 Series Accessories:

- Piped away exhaust kit: 5L-K184
- Horizontal hanger: 7RA-A366
- Dead handle (5LN3): 728N-A48, (requires 2): 6A-49
- Chuck: 6A-99
- Spindle accessories

##### 6 Series Accessories:

- Vertical hanger: 7L-365
- Dead handle: R1A-A48, (requires 2): 6A-49
- Chuck: R00A-99
- Spindle accessories

##### Kits:

- Tune-up kit: 5RA-TK1 (5 Series)
- Tune-up kit: 6-DRILLS-TK1 (6 Series)

Model	in-lbs (Nm)	rpm	lbs (kg)	in (mm)	in (mm)	in (mm)	cfm (L/Min)
<b>C 5 SERIES LEVER START</b>							
5LJ1	20.4 (2.3)	4,800	2.0 (0.9)	8.1" (205)	1/4" (6)	0.8" (20)	16 (453)
5LK1	30.1 (3.4)	3,100	2.0 (0.9)	8.1" (205)	1/4" (6)	0.8" (20)	16 (453)
5LL1	39.8 (4.5)	2,300	2.0 (0.9)	8.1" (205)	1/4" (6)	0.8" (20)	15 (425)
5LN3	79.7 (9.0)	1,000	3.3 (1.5)	9.4" (238)	3/8" (10)	0.8" (20)	15 (425)
<b>C 6 SERIES LEVER START</b>							
6LH1	23 (2.6)	6,000	2.1 (1.0)	7.9" (201)	1/4" (6)	0.8" (20)	20 (560)
6LJ1	27.4 (3.1)	5,100	2.1 (1.0)	7.9" (201)	1/4" (6)	0.8" (20)	20 (560)
6LJJ1	35.4 (4.0)	3,950	2.1 (1.0)	7.9" (201)	1/4" (6)	0.8" (20)	20 (560)
6LK1	45.1 (5.1)	3,100	2.1 (1.0)	7.9" (201)	1/4" (6)	0.8" (20)	20 (560)
6LL1	64.6 (7.3)	2,150	2.1 (1.0)	7.9" (201)	1/4" (6)	0.8" (20)	20 (560)
6LR3	222.2 (25.1)	500	2.9 (1.3)	9.2" (233)	3/8" (10)	0.8" (20)	20 (560)

Series				
5	0.40 hp	75 dBa	1/4" NPT	1/4" (6 mm)
6	0.51 hp	75 dBa	1/4" NPT	3/8" (10 mm)

# Air Production Drills

Inline

## 7800 Series

The 7800 Series drills offer enough power for your toughest applications.

### Features

- Stall Torque: 12 – 654 in-lbs (1.3 – 74.0 Nm)
- Speeds: 325 – 18,000 rpm
- Excellent for production-line drilling of large diameter holes
- Double row ball bearings construction assures max TIR of 0.005" for precise, concentric holes
- Side handle on 325/600 rpm models

### Service and Accessories

#### Manuals:





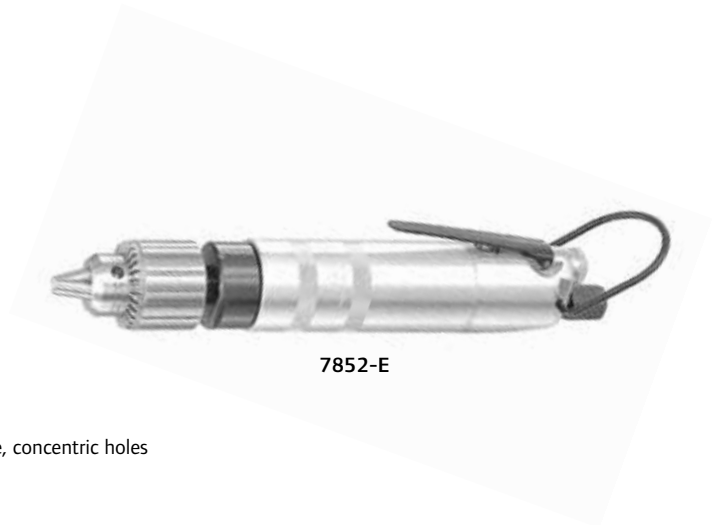

 49999011

#### Accessories:

Spindle accessories



7852-E

Model	 in-lbs (Nm)	 rpm	 lbs (kg)	 in (mm)	 in (mm)	 in (mm)	 cfm (L/Min)
<b>DC LEVER START</b>							
7850-E	12 (1.3)	18,000	3.2 (1.5)	9.6" (244)	3/8" (10)	0.9" (24)	31 (878)
7851-E	48 (5.4)	4,500	3.2 (1.5)	9.6" (244)	3/8" (10)	0.9" (24)	31 (878)
7852-E	90 (10)	2,400	3.2 (1.5)	9.6" (244)	3/8" (10)	0.9" (24)	31 (878)
7853-E	192 (22)	1,100	4.7 (2.1)	11.8" (299)	3/8" (10)	0.9" (24)	31 (878)
7854-E	354 (40)	600	4.7 (2.1)	11.8" (299)	3/8" (10)	0.9" (24)	31 (878)
7855-E	654 (74)	325	4.7 (2.1)	11.8" (299)	3/8" (10)	0.9" (24)	31 (878)

Series					
7800	0.70 hp	88 dBa	1/4" NPT	5/16" (8 mm)	1/2"-20

# Air Production Drills

## Angle

### Q2 Series

Compact and lightweight, Q2 drills deliver more power in a smaller package to get the job done in less time.

#### Features

- Stall Torque: 14 – 110 in-lbs (1.6 – 12.5 Nm)
- Speeds: 500 – 3,500 rpm
- Variable speed control allows slow starting and high speed for fast drilling

- Ergonomically designed housing provides a secure surface for operator grip
- Excellent power-to-weight ratio gets the job done with less fatigue



#### Service and Accessories

##### Manuals:

16572778 16572158 16572653

##### Accessories:

Vertical hanger: 7L-365  
Chuck: ROH-99

##### Kits:

Tune-up kit: Q2-PDRILL-TK1

Model	Max. Nm in-lbs (Nm)	1 min. rpm	lbs (kg)	in (mm)	Max. in (mm)	in (mm)	in (mm)	in (mm)	cfm (L/Min)
<b>LEVER START (90° CHUCK)</b>									
QA2719D	19 (2.2)	2,700	2.07 (0.94)	9.35" (238)	1/4" (6)	3.0" (76)	0.54" (13.6)	16 (450)	
QA2119D	24 (2.8)	2,100	2.07 (0.94)	9.35" (238)	1/4" (6)	3.0" (76)	0.54" (13.6)	16 (450)	
QA1219D	43 (4.9)	1,270	2.07 (0.94)	9.35" (238)	1/4" (6)	3.0" (76)	0.54" (13.6)	16 (450)	
<b>LEVER START (90° SMALL ANGLE HEAD)</b>									
QA3559D	16 (1.8)	3,500	1.4 (0.6)	8.7" (221)	1/4"-28*	1.1" (27)	0.4" (10)	16 (450)	
QA2739D	20 (2.3)	2,700	1.4 (0.6)	8.7" (221)	3/16"***	1.1" (27)	0.4" (10)	16 (450)	
QA2759D	20 (2.3)	2,700	1.4 (0.6)	8.7" (221)	1/4"-28*	1.1" (27)	0.4" (10)	16 (450)	
QA1739D	32 (3.6)	1,750	1.4 (0.6)	8.7" (221)	3/16"***	1.1" (27)	0.4" (10)	16 (450)	
QA1239D	39 (4.5)	1,270	1.4 (0.6)	8.7" (221)	3/16"***	1.1" (27)	0.4" (10)	16 (450)	
QA0859D	67 (7.6)	850	1.4 (0.6)	8.7" (221)	1/4"-28*	1.1" (27)	0.4" (10)	16 (450)	
QA0539D	110 (12.5)	500	1.4 (0.6)	8.7" (221)	3/16"***	1.1" (27)	0.4" (10)	16 (450)	
QA0579D	110 (12.5)	500	1.4 (0.6)	8.7" (221)	3/8"-24***	1.1" (27)	0.4" (10)	16 (450)	
QA0559D	110 (12.5)	500	1.4 (0.6)	8.7" (221)	1/4"-28*	1.1" (27)	0.4" (10)	16 (450)	
<b>LEVER START (45° SMALL ANGLE HEAD)</b>									
QA2754D	17 (1.9)	2,700	1.47 (0.67)	10.55" (268)	1/4"-28*	1.3" (34)	0.3" (8.3)	16 (450)	
QA0854D	57 (6.4)	850	1.47 (0.67)	10.55" (268)	1/4"-28*	1.3" (34)	0.3" (8.3)	16 (450)	
<b>LEVER START (90° X 90° SMALL ANGLE HEAD)</b>									
QA3555D	14 (1.6)	3,500	1.6 (0.73)	9.03" (229)	1/4"-28*	1.1" (27)	0.4" (9.3)	16 (450)	
QA2755D	19 (2.1)	2,700	1.6 (0.73)	9.03" (229)	1/4"-28*	1.1" (27)	0.4" (9.3)	16 (450)	

Series							
Q2	0.28 hp	75 dBa	1/4" NPT	1/4" (6 mm)	1/4"-28 Female Thread	9/32"-40 Female Thread	3/8"-24 Male Thread

# Air Production Drills

## Angle

### 5 Series

Durability and performance are the hallmarks of these proven winners.

#### Features

- Stall Torque: 20 – 120 in-lbs (2.2 – 13.6 Nm)
- Speeds: 700 – 4800 rpm
- Small angle heads designed for close quarters drilling operations
- Excellent power-to-weight ratio gets the job done with less fatigue



5LK1B1

#### Service and Accessories

##### Manuals:

16572786

16572802

##### Accessories:

Horizontal hanger: 6WS-366  
Piped away exhaust kit: 7L-K284  
Chuck: 6A-99

##### Kits:

Tune-up kit: 5A/5L-TK1

Model	in-lbs (Nm)	rpm	lbs (kg)	in (mm)	in (mm)	in (mm)	in (mm)	cfm (L/Min)
<b>C LEVER START (90° CHUCK)</b>								
5LL2A41	60.2 (6.8)	1,500	2.6 (1.2)	9.4" (239)	1/4" (6)	3.0" (75)	0.6" (15)	15 (420)
5LN2A43	120.4 (13.6)	700	3.5 (1.6)	10.2" (259)	3/8" (10)	3.6" (91)	0.6" (15)	15 (420)
<b>C LEVER START (90° X 90° SMALL ANGLE HEAD)</b>								
5LK1A1	31 (3.5)	3,000	2.19 (1.0)	9.8" (249)	1/4"-28 *	1.1" (28)	0.3" (8)	15 (420)
5LL1A1	40 (4.5)	2,200	2.19 (1.0)	9.8" (249)	1/4"-28 *	1.1" (28)	0.3" (8)	15 (420)
<b>C LEVER START (45° SMALL ANGLE HEAD)</b>								
5LK1B1	31 (3.5)	3,000	2.13 (1.0)	9.75" (248)	1/4"-28 *	–	0.3" (8)	15 (420)

Series	0.40 hp	75 dBa	1/4" NPT	1/4" (6 mm)	1/4"-28 Female Thread
5	0.40 hp	75 dBa	1/4" NPT	1/4" (6 mm)	1/4"-28 Female Thread

# Air Production Drills

## Angle

### 6 Series

Dependability and consistency have made the 6 Series drills a staple in many assembly environments.

#### Features

- Stall Torque: 23 – 320 in-lbs (2.6 – 36.2 Nm)
- Speeds: 400 – 6,000 rpm
- Small angle heads designed for close quarters drilling operations
- Excellent power-to-weight ratio gets the job done with less fatigue



6LL2A42

#### Service and Accessories

##### Manuals:

P6784

##### Accessories:

Horizontal hanger: 6WS-366  
Piped away exhaust kit: 7L-K284  
Chuck: 6A-99

##### Kits:

Tune-up kit: 6-DRILLS-TK1

Model	in-lbs (Nm)	rpm	lbs (kg)	in (mm)	in (mm)	in (mm)	in (mm)	cfm (L/Min)
<b>C LEVER START (90° CHUCK)</b>								
6LK2A41	64.6 (7.3)	2,000	2.8 (1.3)	9.5" (241)	1/4" (6)	3.0" (75)	0.5" (14)	20 (560)
6LL2A42	94.7 (10.7)	1,400	2.8 (1.3)	9.5" (242)	3/8" (10)	3.2" (81)	0.5" (14)	20 (560)
6LP3A43	192.1 (21.7)	600	3.7 (1.7)	10.6" (270)	3/8" (10)	3.9" (99)	0.7" (18)	20 (560)
6LR3A44	320.4 (36.2)	400	4.0 (1.8)	10.7" (272)	1/2" (13)	4.1" (105)	0.7" (18)	20 (560)
<b>C LEVER START (90° SMALL ANGLE HEAD)</b>								
6LL1A1	64 (7.3)	2,150	2.13 (0.95)	9.69" (246)	1/4"-28 *	1.1" (28)	0.3" (8)	20 (560)

Series					
6	0.51 hp	74 dBa	1/4" NPT	1/4" (6 mm)	1/4"-28 Female Thread



# Air Production Drills

## Angle

### 7 Series

Durability and performance are the hallmarks of these proven winners.

#### Features

- Stall Torque: 31 – 255 in-lbs (3.5 – 28.1 Nm)
- Speeds: 600 – 6,000 rpm
- Small angle heads designed for close-quarters drilling operations
- Excellent power-to-weight ratio gets the job done with less fatigue



7LN3A44

#### Service and Accessories

##### Manuals:

- 16572794
- 16572174

##### Accessories:

- Horizontal hanger: 6WS-3P66
- Piped away exhaust kit: 7L-K284
- Chuck: 6A-99

##### Kits:

- Tune-up kit: 7L-DRILLS-TK1

Model	in-lbs (Nm)	rpm	lbs (kg)	in (mm)	<i>Max.</i> in (mm)	in (mm)	in (mm)	cfm (L/Min)
<b>C LEVER START (90° CHUCK)</b>								
7LJ2A41	51 (5.6)	3,250	3.0 (1.36)	10.0" (254)	1/4" (6)	2.97" (75)	0.5" (14)	26 (736)
7LL3A42	112 (12.7)	1,550	3.44 (1.56)	10.38" (263)	3/8" (10)	3.66" (93)	0.7" (18)	26 (736)
7LM3A43	170 (18.7)	900	3.9 (1.8)	11.1" (281)	3/8" (10)	3.9" (99)	0.7" (18)	26 (736)
7LN3A44	255 (28.1)	600	4.2 (1.9)	11.1" (281)	1/2" (13)	4.1" (105)	0.7" (18)	26 (736)
<b>C LEVER START (90° SMALL ANGLE HEAD)</b>								
7LK1A1	57 (6.4)	3,200	2.25 (1.02)	10.38" (263)	1/4"-28 *	1.1" (28)	0.3" (8)	26 (736)

Series					
7	0.75 hp	81 dBa	1/4" NPT	1/4" (6 mm)	* 1/4"-28 Female Thread

# Air Production Drills

## Flat Angle

### 7400 Series

The classic 7400 Series flat angle drills offer unrivaled versatility and dependability.

#### Features

- Stall Torque: 48 – 99.6 in-lbs (5.4 – 11.3 Nm)
- Speeds: 1,450 – 3,300 rpm
- Excellent for drilling smaller-diameter holes for airframe builders and metal fab shops
- Flat angle head allows reach into limited access areas

#### Service and Accessories

##### Manuals:









 49999052



##### Accessories:

Swivel air inlets



7439-D

Model	 in-lbs (Nm)	 rpm	 lbs (kg)	 in (mm)	 in (mm)	 in (mm)	 in (mm)	 cfm (L/Min)
<b>C LEVER START FLAT ANGLE DRILLS</b>								
7441-D	48 (5.4)	3,300	2.9 (1.3)	10.6" (269)	1/4"-28*	0.7" (17)	0.5" (13)	24 (660)
7439-D	36 (4.1)	2,500	2.9 (1.3)	10.6" (269)	1/4"-28*	0.7" (17)	0.5" (13)	24 (660)
7438-D	99.6 (11.3)	1,450	3.5 (1.6)	11.9" (302)	1/4"-28*	0.7" (17)	0.5" (13)	24 (660)

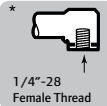
Series				
7400	86 dBa	1/4" NPT	5/16" (8 mm)	1/4"-28 Female Thread

43497-( ) One piece collets, non-precision (used with optional 43494 drive spindle)

Drill Size	Dash Number	Drill Size	Dash Number
8	-8	30	-30
11	-11	40	-40
16	-16	3/32	-163
20	-20	1/8	-165
22	-22	5/32	-167
27	-27	3/16	-169

# Air Production Drills

## Modular

### P33 Series Motors

P33 drills with the R33 modular end effectors offer excellent power and flexibility.

#### Features

- Stall Torque: 16.8 – 141.6 in-lbs (1.9 – 16 Nm)
- Speeds: 660 – 5,400 rpm
- Five unique interchangeable heads that provide the ultimate in flexibility
- 0, 30, 90, and 180 degree angle heads
- Variety of bit holders
- Lube-free

#### Service and Accessories

##### Manuals:







 80218605



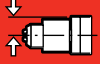

 80212798

##### Accessories:

5 modular attachments



Model	 Max. Nm in-lbs (Nm)	 1 min. rpm	 lbs (kg)	 in (mm)	 in (mm)	 cfm (L/Min)
<b>C PISTOL GRIP / TRIGGER START</b>						
P33054-PMSL	16.8 (1.9)	5,400	1.8 (0.8)	5.7" (146)	0.8" (21)	21 (600)
P33032-PMSL	28.3 (3.2)	3,200	1.8 (0.8)	5.7" (146)	0.8" (21)	21 (600)
P33022-PMSL	39.8 (4.5)	2,200	1.8 (0.8)	5.7" (146)	0.8" (21)	21 (600)
P33016-PMSL	60.2 (6.8)	1,600	2.0 (0.9)	6.3" (161)	0.8" (21)	21 (600)
P33011-PMSL	84.1 (9.5)	1,100	2.0 (0.9)	6.3" (161)	0.8" (21)	21 (600)
P33006-PMSL	141.6 (16)	660	2.0 (0.9)	6.3" (161)	0.8" (21)	21 (600)
<b>C INLINE / BUTTON CONTROL</b>						
P33054-DMSL-B	16.8 (1.9)	5,400	1.4 (0.6)	6.5" (164)	0.9" (22)	21 (600)
P33032-DMSL-B	28.3 (3.2)	3,200	1.4 (0.6)	6.5" (164)	0.9" (22)	21 (600)
<b>C INLINE / LEVER CONTROL</b>						
P33054-DMSL	16.8 (1.9)	5,400	1.5 (0.7)	6.5" (164)	0.9" (22)	21 (600)
P33032-DMSL	28.3 (3.2)	3,200	1.5 (0.7)	6.5" (164)	0.9" (22)	21 (600)
P33022-DMSL	39.8 (4.5)	2,200	1.5 (0.7)	6.5" (164)	0.9" (22)	21 (600)
P33016-DMSL	60.2 (6.8)	1,600	1.7 (0.8)	7.0" (179)	0.9" (22)	21 (600)
P33011-DMSL	84.1 (9.5)	1,100	1.7 (0.8)	7.0" (179)	0.9" (22)	21 (600)
P33006-DMSL	141.6 (16)	660	1.7 (0.8)	7.0" (179)	0.9" (22)	21 (600)

Series				
P33	0.44 hp	76 dBa	1/4" NPT	3/8" (10 mm)

# Air Production Drills

## Modular

### R33 Series Attachments

P33 drills with the R33 modular end effectors offer excellent power and flexibility.

#### Features



- R33 Series precision drilling attachments are designed to quickly, safely, and securely connect with an assortment of pistol and inline motors in a variety of speeds
- Patented quick-change technology allows drill attachment heads to be removed and connected safely, quickly, and securely with any motors in less than three seconds
- Interchangeable heads means you only buy the components you need and configure to the application

#### Service and Accessories

##### Manuals:

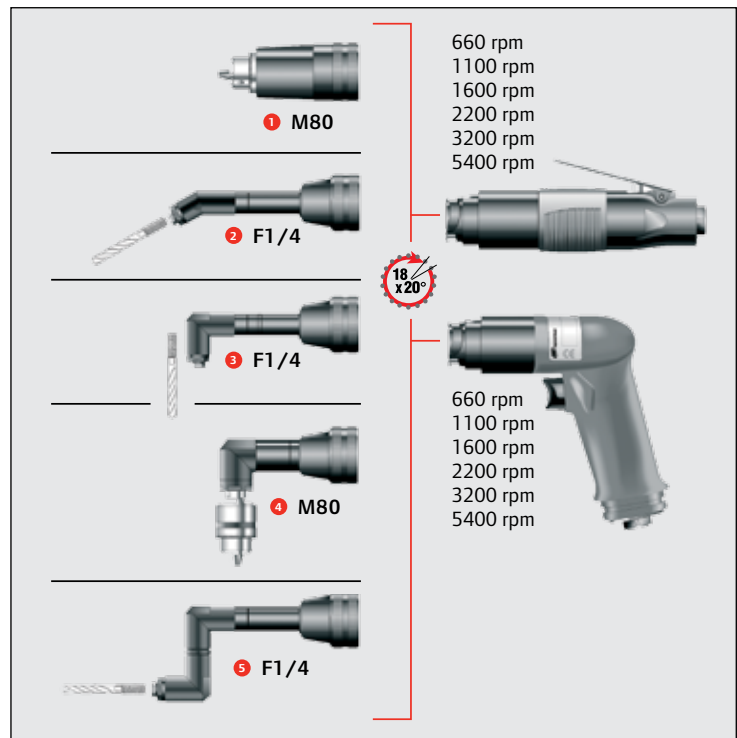
 MBR33001 — 021

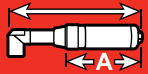

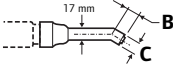
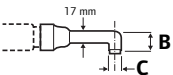
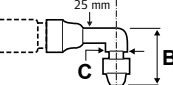
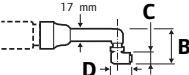
	Reference	Max.  in (mm)	 in (mm)	B in (mm)	C in (mm)	D in (mm)	 lbs (kg)
<b>MODULAR ATTACHMENTS</b>							
	1 R33M000M80	0.3" (8.0)	A + 3.2" (81)	-	-	-	0.8 (0.4)
	2 R33M030D17F1/4	0.3" (6.0)	A + 4.6" (118)	0.9" (24)	0.7" (18)	-	0.5 (0.2)
	3 R33M090D17F1/4	0.3" (6.0)	A + 4.1" (105)	1.4" (36)	0.7" (18)	-	0.5 (0.2)
	4 R33M090D25M80	0.3" (8.0)	A + 3.2" (81)	3.9" (99)	1.2" (30)	-	1.2 (0.5)
	5 R33M180D17F1/4	0.3" (6.0)	A + 4.9" (124)	2.5" (64)	0.7" (18)	1.4" (36)	0.7 (0.3)

# Feed Drills

## Electric/Pneumatic Self-Feed Drills

Bant-A-Matic, Par-A-Matic, and Super Par-A-Matic Drills provide the selection, performance, and degree of precision to automate a wide range of secondary machining applications simply and economically. They utilize compressed air for both the spindle rotation and feed / control functions. The reliable rotary-vane air motor offers high power-to-size performance which minimizes tool size and weight for added machine design flexibility. The tools are easily installed, requiring only simple pneumatic circuitry. They can be used individually or in conjunction with other electric and pneumatic tools.

### Features

- Built-in four-way valve enables both manual and remote operation
- Double-acting air piston provides smooth, controlled forward and retract strokes
- Needle valve controls allows adjustment of forward and retract strokes
- Adjustment screw provides infinite stroke length settings
- Ball bearing spindle support offers precision and long service life
- Muffled exhaust for a quieter work environment

Example of product identification 8 2 55 - A 21 - 2

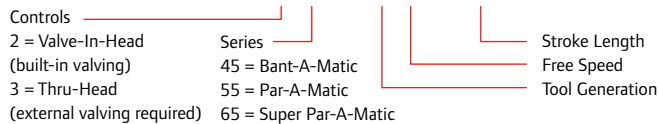

## BANT-A-MATIC® 45 Series

3/16" (4.8 mm) Capacity, Steel • .25 HP (.20 kW)



8245-B45-2

## PARA-A-MATIC® 55 Series

5/16" (7.9 mm) Capacity, Steel • .50 HP (.37 kW)



8255-A14-2

## SUPER PARA-A-MATIC® 65 Series

1/2" (12.7 mm) Capacity, Steel • .75 HP (.56 kW)



8265-25-3

Model	Stroke Lengths in (mm)	Free Speed rpm	*NOMINAL DRILLING CAPACITIES				Thrust @ 90psi lbs (N)	Air Cons. † at Working Speed ft³/cycle (L/cycle)	Sound Level dBa	Standard Chuck Capacity in (mm)	Gear Reduction
			Stainless Steel Type 304	Steel SAE 1213	Aluminum 2024-T4	Wood Med. or FRP					
<b>BANT-A-MATIC SERIES</b>											
8245-203-1*	1-1/4" (32)	19,000	—	1/64 (0.4)	1/32 (0.8)	1/16 (1.6)					Single
8245-101-1	1-1/4" (32)	10,000	1/64 (0.4)	1/32 (0.8)	1/16 (1.6)	1/8 (3.2)					Double
8245-B45-1	1-1/4" (32)	4,400	1/32 (0.8)	1/16 (1.6)	1/8 (3.2)	5/32 (4.0)	90 (400)	1.5 (42)	77	1/4 (6.4)	Single
8245-B30-1	1-1/4" (32)	2,700	1/16 (1.6)	1/8 (3.2)	3/16 (4.8)	3/16 (4.8)					Single
8245-B8-1	1-1/4" (32)	900	3/32 (2.4)	3/16 (4.8)	1/4 (6.4)	5/16 (7.9)					Double
8245-203-2	2.0" (51)	19,000	—	1/64 (0.4)	1/32 (0.8)	1/16 (1.6)					Single
8245-101-2	2.0" (51)	10,000	1/64 (0.4)	1/32 (0.8)	1/16 (1.6)	1/8 (3.2)					Double
8245-B45-2	2.0" (51)	4,400	1/32 (0.8)	1/16 (1.6)	1/8 (3.2)	5/32 (4.0)	90 (400)	1.5 (42)	77	1/4 (6.4)	Single
8245-B30-2	2.0" (51)	2,700	1/16 (1.6)	1/8 (3.2)	3/16 (4.8)	3/16 (4.8)					Single
8245-B8-2	2.0" (51)	900	3/32 (2.4)	3/16 (4.8)	1/4 (6.4)	5/16 (7.9)					Double
8245-203-3	3.0" (76)	19,000	—	1/64 (0.4)	1/32 (0.8)	1/16 (1.6)					Single
8245-101-3	3.0" (76)	10,000	1/64 (0.4)	1/32 (0.8)	1/16 (1.6)	1/8 (3.2)					Double
8245-B45-3	3.0" (76)	4,400	1/32 (0.8)	1/16 (1.6)	1/8 (3.2)	5/32 (4.0)	90 (400)	1.5 (42)	77	1/4 (6.4)	Single
8245-B30-3	3.0" (76)	2,700	1/16 (1.6)	1/8 (3.2)	3/16 (4.8)	3/16 (4.8)					Single
8245-B8-3	3.0" (76)	900	3/32 (2.4)	3/16 (4.8)	1/4 (6.4)	5/16 (7.9)					Double
<b>PAR-A-MATIC SERIES</b>											
*8255-172-1	1-1/4" (32)	17,000	—	1/64 (0.4)	1/32 (0.8)	1/16 (1.6)					Single
8255-101-1	1-1/4" (32)	10,000	—	1/32 (0.8)	1/16 (1.6)	5/32 (4.0)					Double
8255-A50-1	1-1/4" (32)	5,000	—	5/64 (2.0)	3/16 (4.8)	3/16 (4.8)					Single
8255-A28-1	1-1/4" (32)	2,800	1/16 (1.6)	9/64 (3.6)	1/4 (6.4)	1/4 (6.4)					Single
8255-A21-1	1-1/4" (32)	2,100	7/64 (2.8)	7/32 (5.6)	9/32 (7.1)	5/16 (7.9)	170 (756)	2.3 (65)	74	5/16 (7.9)	Single
8255-A14-1	1-1/4" (32)	1,450	5/32 (4.0)	1/4 (6.4)	5/16 (7.9)	3/8 (9.5)					Double
8255-A8-1	1-1/4" (32)	850	11/64 (4.4)	9/32 (7.1)	21/64 (8.3)	25/64 (9.9)					Double
8255-A5-1	1-1/4" (32)	500	1/4 (6.4)	5/16 (7.9)	11/32 (8.7)	13/32 (10.3)					Double

(continued next page)

# Feed Drills Electric/Pneumatic Self-Feed Drills

Model	Stroke Lengths in (mm)	Free Speed rpm	*NOMINAL DRILLING CAPACITIES				Thrust @ 90psi lbs (N)	Air Consp.‡ at Working Speed ft³/cycle (L/cycle)	Sound Level dBa	Standard Chuck Capacity in (mm)	Gear Reduction
			Stainless Steel Type 304	Steel SAE 1213	Aluminum 2024-T4	Wood Med. or FRP					
<b>PAR-A-MATIC SERIES (continued)</b>											
8255-172-2	2.0" (51)	17,000	—	1/64 (0.4)	1/32 (0.8)	1/16 (1.6)				Single	
8255-101-2	2.0" (51)	10,000	—	1/32 (0.8)	1/16 (1.6)	5/32 (4.0)				Double	
8255-A50-2	2.0" (51)	5,000	—	5/64 (2.0)	3/16 (4.8)	3/16 (4.8)				Single	
8255-A28-2	2.0" (51)	2,800	1/16 (1.6)	9/64 (3.6)	1/4 (6.4)	1/4 (6.4)				Single	
8255-A21-2	2.0" (51)	2,100	7/64 (2.8)	7/32 (5.6)	9/32 (7.1)	5/16 (7.9)	170 (756)	2.3 (65)	74	5/16 (79)	
8255-A14-2	2.0" (51)	1,450	5/32 (4.0)	1/4 (6.4)	5/16 (7.9)	3/8 (9.5)				Double	
8255-A8-2	2.0" (51)	850	11/64 (4.4)	9/32 (7.1)	21/64 (8.3)	25/64 (9.9)				Double	
8255-A5-2	2.0" (51)	500	1/4 (6.4)	5/16 (7.9)	11/32 (8.7)	13/32 (10.3)				Double	
8255-172-3	3.0" (76)	17,000	—	1/64 (0.4)	1/32 (0.8)	1/16 (1.6)				Single	
8255-101-3	3.0" (76)	10,000	—	1/32 (0.8)	1/16 (1.6)	5/32 (4.0)				Double	
8255-A50-3	3.0" (76)	5,000	—	5/64 (2.0)	3/16 (4.8)	3/16 (4.8)				Single	
8255-A28-3	3.0" (76)	2,800	1/16 (1.6)	9/64 (3.6)	1/4 (6.4)	1/4 (6.4)				Single	
8255-A21-3	3.0" (76)	2,100	7/64 (2.8)	7/32 (5.6)	9/32 (7.1)	5/16 (7.9)	170 (756)	2.3 (65)	74	5/16 (79)	
8255-A14-3	3.0" (76)	1,450	5/32 (4.0)	1/4 (6.4)	5/16 (7.9)	3/8 (9.5)				Double	
8255-A8-3	3.0" (76)	850	11/64 (4.4)	9/32 (7.1)	21/64 (8.3)	25/64 (9.9)				Double	
8255-A5-3	3.0" (76)	500	1/4 (6.4)	5/16 (7.9)	11/32 (8.7)	13/32 (10.3)				Double	
<b>SUPER PAR-A-MATIC SERIES</b>											
*8265-171-1	1-1/2" (38)	17,000	—	1/64 (0.4)	3/32 (2.4)	3/32 (2.4)				Single	
8265-101-1	1-1/2" (38)	10,000	—	3/64 (1.2)	5/32 (4.0)	5/32 (4.0)				Double	
8265-46-1	1-1/2" (38)	4,600	—	1/8 (3.2)	1/4 (6.4)	5/16 (7.9)				Single	
8265-25-1	1-1/2" (38)	2,500	3/32 (2.4)	3/16 (4.8)	5/16 (7.9)	7/16 (11.1)	250 (1112)	2.9 (82)	77	1/2 (12.7)	
8265-12-1	1-1/2" (38)	1,200	5/32 (4.0)	5/16 (7.9)	3/8 (9.5)	9/16 (14.3)				Double	
8265-6-1	1-1/2" (38)	650	17/64 (6.7)	7/16 (11.1)	9/16 (14.3)	5/8 (15.9)				Double	
8265-3-1	1-1/2" (38)	350	5/16 (7.9)	1/2 (12.7)	5/8 (15.9)	11/16 (17.5)				Double	
8265-171-3	3.0" (76)	17,000	—	1/64 (0.4)	3/32 (2.4)	3/32 (2.4)				Single	
8265-101-3	3.0" (76)	10,000	—	3/64 (1.2)	5/32 (4.0)	5/32 (4.0)				Double	
8265-46-3	3.0" (76)	4,600	—	1/8 (3.2)	1/4 (6.4)	5/16 (7.9)				Single	
8265-25-3	3.0" (76)	2,500	3/32 (2.4)	3/16 (4.8)	5/16 (7.9)	7/16 (11.1)	250 (1112)	2.9 (82)	77	1/2 (12.7)	
8265-12-3	3.0" (76)	1,200	5/32 (4.0)	5/16 (7.9)	3/8 (9.5)	9/16 (14.3)				Double	
8265-6-3	3.0" (76)	650	17/64 (6.7)	7/16 (11.1)	9/16 (14.3)	5/8 (15.9)				Double	
8265-3-3	3.0" (76)	350	5/16 (7.9)	1/2 (12.7)	5/8 (15.9)	11/16 (17.5)				Double	

\*NOTE: 17,000 & 19,000 RPM units have collet in Spindle. See Pages 52, 54 & 56. ‡Consumption in cubic feet during a typical 6 second cycle time. Note: Performance data given at 90 PSI (6.2 bar) operating pressure.

Tool Series	Air Inlet	Control Ports	Spindle Threads	Recommended Hose Size	Recommended Operating Pressure
Bant-A-Matic	1/8" NPT male	1/8" NPTF female	1/2"-20 male	1/4" ID	90 PSI (6.2 bar)
Par-A-Matic	1/4" NPT male	1/8" NPTF female	1/2"-20 male	5/16" ID	90 PSI (6.2 bar)
Super Par-A-Matic	1/4" NPT male	1/8" NPTF female	1/2"-20 male	3/8" ID	90 PSI (6.2 bar)

To order a "thru-head" tool (requires an external four-way valve for controls), change the "2" in the base model number to "3" (Bant-A-Matic and Par-A-Matic Series tools only). EXAMPLE: 8355-A21-2. Thru-head tools available in Super Par-A-Matic series only as a custom order tool. 47884 Pneumatic Interface Kit contains 2 each of 6045 elbow and 9600 bleeder valve.

### Standard Equipment

- Bant-A-Matic Series**
- 33906 1/4" (6.4 mm) Cap. Chuck\*
  - 47884 Pneumatic Controls Interface Kit\*
  - 203 UNITS have collet built-in spindle instead of chuck. See page 63 for selection of collet

- Par-A-Matic Series**
- 33907 3/8" (9.5 mm) Cap. Chuck\*
  - 47884 Pneumatic Controls Interface Kit\*
  - 172 UNITS have collet built-in spindle instead of chuck. See page 63 for selection of collet

- Super Par-A-Matic Series**
- 30018 1/2" (12.7 mm) Cap. Chuck\*
  - 47884 Pneumatic Controls Interface Kits\*
  - 171 UNITS have collet built-in spindle instead of chuck. See page 63 for selection of collet

### Accessories at Extra Cost

- 40301-( ) Hydraulic Checks
- 39486 Flange Bracket
- 39485-1 Foot Bracket
- 45053 H.D. Foot Bracket
- 36042 Split-Block Clamp
- Nose Housings
- Drill Bushing Adapters
- Control Kits
- Service Kits

- 40591-( ) Hydraulic Checks
- 38877 Flange Bracket
- 38875-1 Foot Bracket
- 45055 H.D. Foot Bracket
- 35283 Split-Block Clamp
- Nose Housings
- Drill Bushing Adapters
- Control Kits
- Service Kits

- 40591-( ) Hydraulic Checks
- 40589 Flange Bracket
- 40588-1 Foot Bracket
- 45056 H.D. Foot Bracket
- 41454 Collet-Type Foot Bracket
- Nose Housings
- Nose Housing Adapters
- Drill Bushing Adapters
- Control Kits
- Service Kits

# Feed Drills

## Electric/Pneumatic Self-Feed Twin Drills

Twin Drills perform two machining operations per cycle for holes with center distances from 3/8" to 3 3/4". They're ideal for many close-center machining problems. But even more important, Twin Drills significantly reduce machining time and parts handling while improving quality.

Three series of standard tools are available, equipped with adjustable dual spindle heads. Like the other Automatic Production Tools, each Twin Drill is a completely self-contained unit with built-in cycle, feed rate, and motor controls. They can be operated individually or in conjunction with other tools and machine components.

### Features

- Adjustable spindles allow reapplication as machining requirements change.
- Comprehensive range of American and metric collets available to meet a wide variety of hole specifications.
- Double-acting air piston provides smooth, controlled forward and retract strokes.
- Needle valve controls allow adjustment of forward and retract strokes.
- Adjustment screw provides infinite stroke length settings up to 3.0" maximum.
- Muffled exhaust for a quieter work environment.

Example of product identification 8 2 58 - C 21 - 2

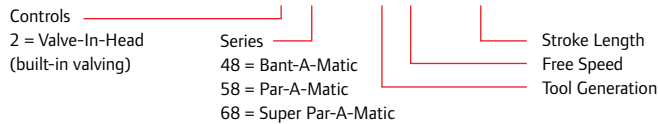

## BANT-A-MATIC® 48 Series

1/8" (3.2 mm) Capacity, Steel • .25 HP (.19 kW)



MODEL 8248-B30-2

## PARA-A-MATIC® 58 Series

1/4" (6.4 mm) Capacity, Steel • .50 HP (.37 kW)



MODEL 8258-C21-2

## SUPER PARA-A-MATIC® 68 Series

3/8" (9.5 mm) Capacity, Steel • .75 HP (.56 kW)



MODEL 8268-A25-3

Model	Stroke Lengths in (mm)	Free Speed rpm	*NOMINAL DRILLING CAPACITIES				Thrust @ 90psi lbs (N)	Air Consp. ‡ at Working Speed ft³/cycle (L/cycle)	Sound Level dBA	Standard Chuck Capacity in (mm)	Gear Reduction
			Stainless Steel Type 304	Steel SAE 1213	Aluminum 2024-T4	Wood Med. or FRP					
<b>BANT-A-MATIC SERIES</b>											
8248-B45-1	1-1/4" (32)	4,400	1/32 (.78)	1/16 (1.6)	3/32 (2.4)	3/32 (2.4)					Single
8248-B30-1	1-1/4" (32)	2,700	1/16 (1.6)	3/32 (2.4)	1/8 (3.2)	1/8 (3.2)	90 (400)	1.5 (42)	77	5/32(4.0)	Single
8248-B8-1	1-1/4" (32)	900	1/8 (3.2)	1/8 (3.2)	3/16 (4.8)	3/16 (4.8)					Double
8248-B45-2	2.0" (51)	4,400	1/32 (.78)	1/16 (1.6)	3/32 (2.4)	3/32 (2.4)					Single
8248-B30-2	2.0" (51)	2,700	1/16 (1.6)	3/32 (2.4)	1/8 (3.2)	1/8 (3.2)	90 (400)	1.5 (42)	77	5/32(4.0)	Single
8248-B8-2	2.0" (51)	900	1/8 (3.2)	1/8 (3.2)	3/16 (4.8)	3/16 (4.8)					Double
8248-B45-3	3.0" (76)	4,400	1/32 (.78)	1/16 (1.6)	3/32 (2.4)	3/32 (2.4)					Single
8248-B30-3	3.0" (76)	2,700	1/16 (1.6)	3/32 (2.4)	1/8 (3.2)	1/8 (3.2)	90 (400)	1.5 (42)	77	5/32(4.0)	Single
8248-B8-3	3.0" (76)	900	1/8 (3.2)	1/8 (3.2)	3/16 (4.8)	3/16 (4.8)					Double
<b>PAR-A-MATIC SERIES</b>											
8258-C50-1	1-1/4" (32)	5,000		1/16 (1.6)	1/8 (3.2)	1/8 (3.2)					Single
8258-C28-1	1-1/4" (32)	2,800	3/64 (1.2)	1/8 (3.2)	3/16 (4.5)	3/16 (4.5)					Single
8258-C21-1	1-1/4" (32)	2,100	5/64 (1.9)	5/32 (4.0)	7/32 (5.6)	7/32 (5.6)	170 (756)	2.3 (65)	74	1/4 (6.4)	Single
8258-C14-1	1-1/4" (32)	1,450	7/64 (2.7)	3/16 (4.5)	1/4 (6.4)	1/4 (6.4)					Double
8258-C8-1	1-1/4" (32)	850	11/64 (4.3)	1/4 (6.4)	9/32 (7.1)	9/32 (7.1)					Double
8258-C5-1	1-1/4" (32)	500	1/4 (6.4)	1/4 (6.4)	5/16 (7.9)	5/16 (7.9)					Double
8258-C50-2	2.0" (51)	5,000		1/16 (1.6)	1/8 (3.2)	1/8 (3.2)					Single
8258-C28-2	2.0" (51)	2,800	3/64 (1.2)	1/8 (3.2)	3/16 (4.5)	3/16 (4.5)					Single
8258-C21-2	2.0" (51)	2,100	5/64 (1.9)	5/32 (4.0)	7/32 (5.6)	7/32 (5.6)	170 (756)	2.3 (65)	74	1/4 (6.4)	Single
8258-C14-2	2.0" (51)	1,450	7/64 (2.7)	3/16 (4.5)	1/4 (6.4)	1/4 (6.4)					Double
8258-C8-2	2.0" (51)	850	11/64 (4.3)	1/4 (6.4)	9/32 (7.1)	9/32 (7.1)					Double
8258-C5-2	2.0" (51)	500	1/4 (6.4)	1/4 (6.4)	5/16 (7.9)	5/16 (7.9)					Double

(continued next page)

# Feed Drills

## Electric/Pneumatic Self-Feed Twin Drills

Model	Stroke Lengths in (mm)	Free Speed rpm	*NOMINAL DRILLING CAPACITIES				Thrust @ 90psi lbs (N)	Air Consp. ‡ at Working Speed ft³/cycle (L/cycle)	Sound Level dBa	Standard Chuck Capacity in (mm)	Gear Reduction
			Stainless Steel Type 304	Steel SAE 1213	Aluminum 2024-T4	Wood Med. or FRP					
<b>PAR-A-MATIC SERIES (continued)</b>											
8258-C50-3	3.0" (76)	5,000		1/16 (1.6)	1/8 (3.2)	1/8 (3.2)				Single	
8258-C28-3	3.0" (76)	2,800	3/64 (1.2)	1/8 (3.2)	3/16 (4.5)	3/16 (4.5)				Single	
8258-C21-3	3.0" (76)	2,100	5/64 (1.9)	5/32 (4.0)	7/32 (5.6)	7/32 (5.6)	170 (756)	2.3 (65)	74	1/4 (6.4)	
8258-C14-3	3.0" (76)	1,450	7/64 (2.7)	3/16 (4.5)	1/4 (6.4)	1/4 (6.4)				Double	
8258-C8-3	3.0" (76)	850	11/64 (4.3)	1/4 (6.4)	9/32 (7.1)	9/32 (7.1)				Double	
8258-C5-3	3.0" (76)	500	1/4 (6.4)	1/4 (6.4)	5/16 (7.9)	5/16 (7.9)				Double	
<b>SUPER PAR-A-MATIC SERIES (continued)</b>											
8268-A46-1	1-1/2" (38)	4,600			1/4 (6.4)	3/16 (4.8)				Single	
8268-A25-1	1-1/2" (38)	2,500	1/16 (1.6)	1/4 (6.4)	5/16 (7.9)	5/16 (7.9)				Single	
8268-A12-1	1-1/2" (38)	1,200	1/8 (3.2)	5/16 (7.9)	11/32 (8.7)	3/8 (9.5)	250 (1112)	2.9 (82)	77	3/8 (9.5)	
8268-A6-1	1-1/2" (38)	650	13/64 (5.2)	11/32 (8.7)	3/8 (9.5)	7/16 (11.1)				Double	
8268-A3-1	1-1/2" (38)	350	5/16 (7.9)	3/8 (9.5)	13/32 (10.3)	15/32 (11.9)				Double	
8268-A46-3	3.0" (76)	4,600			1/4 (6.4)	3/16 (4.8)				Single	
8268-A25-3	3.0" (76)	2,500	1/16 (1.6)	1/4 (6.4)	5/16 (7.9)	5/16 (7.9)				Single	
8268-A12-3	3.0" (76)	1,200	1/8 (3.2)	5/16 (7.9)	11/32 (8.7)	3/8 (9.5)	250 (1112)	2.9 (82)	77	3/8 (9.5)	
8268-A6-3	3.0" (76)	650	13/64 (5.2)	11/32 (8.7)	3/8 (9.5)	7/16 (11.1)				Double	
8268-A3-3	3.0" (76)	350	5/16 (7.9)	3/8 (9.5)	13/32 (10.3)	15/32 (11.9)				Double	

\*Speed Sensitive Material ‡Consumption in cubic feet during a typical 6 second cycle time. Note: Performance data given at 90 PSI (6.2 bar) operating pressure.

Tool Series	Air Inlet	Control Ports	Spindle Adjustments	Recommended Hose Size	Recommended Operating Pressure
Bant-A-Matic	1/8" NPT male	1/8" NPTF female	3/8" to 2 1/8" centers (9.5 to 54 mm)	1/4" ID	90 PSI (6.2 bar)
Par-A-Matic	1/4" NPT male	1/8" NPTF female	1/2" to 2 1/2" centers (12.7 to 63.5 mm)	5/16" ID	90 PSI (6.2 bar)
Super Par-A-Matic	1/4" NPT male	1/8" NPTF female	3/4" to 3 3/4" centers (19 to 95 mm)	3/8" ID	90 PSI (6.2 bar)

### Standard Equipment

- Bant-A-Matic Series
- 46394 Twin Drill Head
  - 47884 Pneumatic Controls Interface Kit\*
  - Necessary Wrenches

- Par-A-Matic Series
- 46023 Twin Drill Head
  - 47884 Pneumatic Controls Interface Kit\*
  - Necessary Wrenches

- Super Par-A-Matic Series
- 46063 Twin Drill Head
  - 47884 Pneumatic Controls Interface Kit\*
  - Necessary Wrenches

\*Contains (2) 6045 90° street elbows and (2) 9600 pilot bleeder valves. NOTE: Collets for Twin Drills must be ordered separately at extra cost. See page 28.

### Accessories at Extra Cost

- 47368-( ) Collets
- 40301-( ) Hydraulic Checks
- 39486 Flange Bracket
- 39485-1 Foot Bracket
- 45053 H.D. Foot Bracket
- 36042 Split-Block Clamp
- Control Kits
- Service Kits

- 45998-( ) Collets
- 40591-( ) Hydraulic Checks
- 38877 Flange Bracket
- 38875-1 Foot Bracket
- 45055 H.D. Foot Bracket
- 35283 Split-Block Clamp
- Control Kits
- Service Kits

- 46033-( ) Collets
- 40591-( ) Hydraulic Checks
- 40589 Flange Bracket
- 40588-1 Foot Bracket
- 45056 H.D. Foot Bracket
- 41454 Collet-Type Foot Bracket
- Control Kits
- Service Kits



# Feed Drills

## Pneumatic Self-Feed Offset Drills

Automatic Offset Drills are offered to accommodate unusual part or fixture configurations. They also may be grouped in a fixture to produce holes with a center-line distance as low as 1.5".

Offset drills are easily installed, requiring only simple pneumatic circuitry. They may also be used in conjunction with other pneumatic or electric Automatic Production Tools.

### Features

- Built-in four-way valve for both manual and remote operation.
- Double-acting air piston provides smooth, controlled forward and retract strokes.
- Infinite stroke length adjustment up to 2.0" maximum.
- Feed rate adjustment screws for the forward and retract strokes provide optimum hole quality and cycle time.
- Muffled exhaust for a more comfortable work environment.
- Selection of mounting brackets to meet installation requirements.

### PAR-A-MATIC® 66 Series

3/16" (4.8 mm) Capacity, Steel • 50 HP (.37 kW)

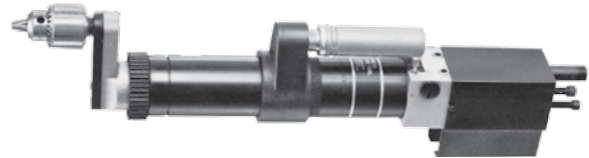

MODEL 8266-A17-2

Model	Free Speed rpm	NOMINAL DRILLING CAPACITIES				Thrust @ 90psi lbs (N)	Air Consp.† at Working Speed ft³/cycle (L/cycle)	Sound Level dBa	Standard Chuck Capacity in (mm)	Gear Reduction
		Stainless Steel Type 304	Steel SAE 1213	Aluminum 2024-T4	Wood Med. or FRP					
PAR-A-MATIC SERIES										
8266-A23-2	2,300	N/A	1/16 (1.6)	1/8 (3.2)	3/16 (4.8)					Double
8266-A17-2	1,700	N/A	3/32 (2.4)	5/32 (4.0)	7/32 (5.6)	170 (756)	2.3 (65)	74	3/8 (9.5)	Double
8266-A12-2	1,200	N/A	5/32 (4.0)	3/16 (4.8)	1/4 (6.4)					Double
8266-A7-2	700	N/A	3/16 (4.8)	7/32 (5.6)	9/32 (7.2)					Double

†Consumption in cubic feet during a typical 6 second cycle time. Note: Performance data given at 90 PSI (6.2 bar) air pressure.

Tool Series	Air Inlet	Control Ports	Spindle Adjustments	Recommended Hose Size	Recommended Operating Pressure
Par-A-Matic	1/4" NPT male	1/8" NPTF female	3/8"-24 male	5/16" ID	90 PSI (6.2 bar)

#### Standard Equipment

- Par-A-Matic Series
- 47341 3/8" (9.5 mm) Cap. Chuck
- 47884 Pneumatic Controls Interface Kit
  - contains (2) 6045 90° streetelbows and (2) 9600 pilot bleeder valves

#### Accessories at Extra Cost

- 40591-( ) Hydraulic Checks
- 38877 Flange Bracket
- 38875-1 Foot Bracket
- 45055 H.D. Foot Bracket
- 35283 Split-Block Clamp
- Control Kits
- Service Kits

# Feed Drills

## Pneumatic Self-Feed Drills

Hi-Thrust Automatic Feed Drills are designed for increased material removal rates of standard alloys and non-ferrous materials. Their high power and thrust also enable the machining of even the most demanding materials, including titanium and high-nickel alloys.

Hi-Thrust Drills feature a dual piston which develops the increased thrust for fast penetration and reduced cycle times. The tools are fully automatic, with all cycle and motor functions regulated by a single control module. They are easily installed, requiring only simple pneumatic circuitry. Hi-Thrust Drills can also be used in conjunction with other pneumatic and electric Automatic Production Tools.

### Features

- Adjustable hydraulic check provides positive feed rate control for fine adjustment of chip size or breakthrough control.
- “Dead stop” and “dwell” control offer repeatable depth accuracy within .001”.
- Heavy-duty cast iron housing for rigid mounting.
- Constant tool length, regardless of spindle speed, allows speed change without repositioning the tool.
- Both coarse and fine stroke length adjustments enables quick, accurate setups.
- Control module is a complete, replaceable unit and can be easily removed without tool disassembly.
- Modular motor and gearing units enable fast, easy speed changes and servicing.
- Single exterior lubrication point for entire gear train simplifies preventative maintenance.
- Muffled exhaust for a more comfortable work environment.
- Exhaust may be piped away.

## HIGH-THRUST 8670 Series

5/8" (15.9 mm) Capacity, Steel • 1.25 HP (.93 kW)

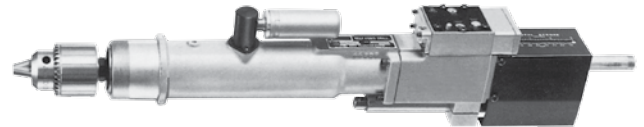

8670-28-1

Example of product identification

86 70 - 28 -3 - - -

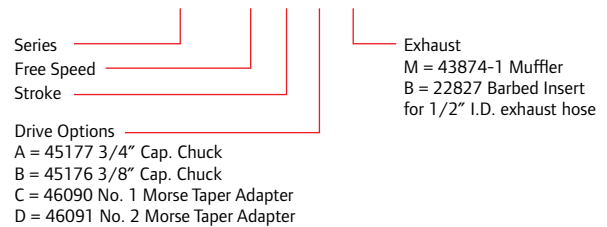

Model	Stroke Length in (mm)	Free Speed rpm	NOMINAL DRILLING CAPACITIES				Thrust @ 90psi lbs (N)	Air Consp.† at Working Speed ft <sup>3</sup> /cycle (L/cycle)	Sound Level dBa	Standard Chuck Capacity in (mm)
			Stainless Steel Type 304	Steel SAE 1213	Aluminum 2024-T4	Wood Med. or FRP				
<b>HIGH THRUST SERIES</b>										
8670-47-3		4,700	—	3/16 (4.75)	7/16 (11.1)	1/2 (12.7)				
8670-28-3		2,800	3/16 (4.8)	1/4 (6.35)	9/16 (14.3)	5/8 (15.9)				
8670-13-3AM	3.0 (76)	1,350	5/16 (7.9)	11/32 (8.73)	5/8 (15.9)	3/4 (19.0)	500 (2224)	5.0 (142)	80	3/4 (19.0)
8670-8-3AM		800	3/8 (9.5)	7/16 (11.11)	3/4 (19.0)	7/8 (22.2)				
8670-4-3		450	1/2 (12.7)	5/8 (15.87)	7/8 (22.2)	1.0 (25.4)				

†Consumption in cubic feet during a typical 6 second cycle time. Note: Performance data given at 90 PSI (6.2 bar) air pressure.

Tool Series	Air Inlet	Control Ports	Spindle Adjustments	Recommended Hose Size	Recommended Operating Pressure	Coupler/ Connection	F/R/L
High-Thrust	3/8" NPT male	1/8" NPTF female	5/8"-16 male	5/8" ID	90 PSI (6.2 bar)	1/2"	1/2"

### Standard Equipment

- 45177 3/4" (19 mm) Cap. Chuck
- 38922-1 2.0" Hydraulic Check
- 45940 Exhaust Manifold
- 43874-1 Muffler or 2632 Barbed Insert
- Necessary wrenches
- 45176 3/8" (9.5 mm) Cap. Chuck
- 46090 No. 1 Morse Taper Adapter
- 46091 No. 2 Morse Taper Adapter

### Accessories at Extra Cost

- 38922-2 3.0" Hydraulic Check
- 46133-( ) Twin Hydraulic Check Assembly
- 45185 Foot Bracket
- 45188 Nose Housing
- 46093-( ) Collets

# Tappers

## Pneumatic Self-Feed Tappers

These tools are identical to the Bant-A-Matic and Par-A-Matic units described on pages 12 and 13, except that these are fitted with tapping heads. All models are completely self-contained and have an adjustable stroke length of 2.0" maximum.

These tools are ideal for low-cost, automated hole tapping in applications where high precision is not required. Also excellent for thread-chasing operations.

*Clutch-type tapping units may be used for both blind and thru-hole applications. Jaw-type units are for use in thru-hole applications only.*

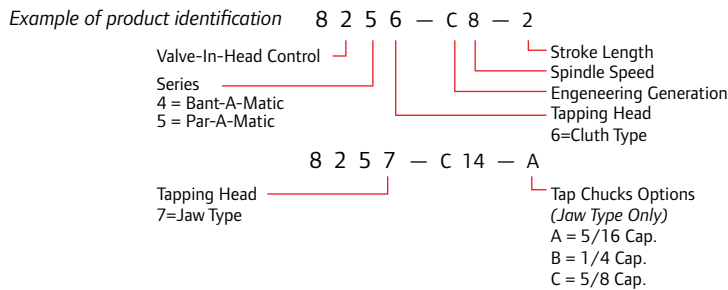

## BANT-A-MATIC® Series

Clutch-Type Tapping Head  
No. 0 to 1/4" (M1.6 to M6) Capacity, Steel  
.25 HP (.20 kW)



8246-D8-2

## PARA-A-MATIC® Series

Clutch-Type Tapping Head  
No. 0 to 1/2" (M1.6 to M12) Capacity, Steel  
.50 HP (.37 kW)



8256-C8-2

## SUPER PARA-A-MATIC® Series

Jaw-Type Tapping Head  
No. 10 to 5/16" (M4.5 to M8) Capacity, Steel  
.50 HP (.37 kW)



MODEL 8257-A8-( )

Model	Stroke Lengths in (mm)	Free Speed rpm	NOMINAL TAP CAPACITIES				Thrust @ 90psi lbs (N)	Air Cons. † at Working Speed ft³/cycle (L/cycle)	Sound Level dBa	Standard Chuck Capacity in (mm)	Gear Reduction
			Stainless Steel Type 304	Steel SAE 1213	Aluminum 2024-T4	Wood Med. or FRP					
<b>BANT-A-MATIC SERIES</b>											
8245-203-1*	1-1/4" (32)	19,000	—	1/64 (0.4)	1/32 (0.8)	1/16 (1.6)					Single
8245-101-1	1-1/4" (32)	10,000	1/64 (0.4)	1/32 (0.8)	1/16 (1.6)	1/8 (3.2)					Double
8245-B45-1	1-1/4" (32)	4,400	1/32 (0.8)	1/16 (1.6)	1/8 (3.2)	5/32 (4.0)	90 (400)	1.5 (42)	77	1/4 (6.4)	Single
8245-B30-1	1-1/4" (32)	2,700	1/16 (1.6)	1/8 (3.2)	3/16 (4.8)	3/16 (4.8)					Single
8245-B8-1	1-1/4" (32)	900	3/32 (2.4)	3/16 (4.8)	1/4 (6.4)	5/16 (7.9)					Double
8245-203-2	2.0" (51)	19,000	—	1/64 (0.4)	1/32 (0.8)	1/16 (1.6)					Single
8245-101-2	2.0" (51)	10,000	1/64 (0.4)	1/32 (0.8)	1/16 (1.6)	1/8 (3.2)					Double
8245-B45-2	2.0" (51)	4,400	1/32 (0.8)	1/16 (1.6)	1/8 (3.2)	5/32 (4.0)	90 (400)	1.5 (42)	77	1/4 (6.4)	Single
8245-B30-2	2.0" (51)	2,700	1/16 (1.6)	1/8 (3.2)	3/16 (4.8)	3/16 (4.8)					Single
8245-B8-2	2.0" (51)	900	3/32 (2.4)	3/16 (4.8)	1/4 (6.4)	5/16 (7.9)					Double

† Consumption in cubic feet during a typical 6 second cycle time. \*\*Tapping capacity is limited by the capacity of the tap chuck.  
NOTE: Performance data given at 90 PSI (6.2 bar) air pressure.

Tool Series	Air Inlet	Control Ports	Spindle Thread	Recommended Hose Size	Recommended Operating Pressure
Bant-A-Matic	1/8" NPT male	1/8" NPTF female	1/2" to 20" male	1/4" ID	90 PSI (6.2 bar)
Par-A-Matic	1/4" NPT male	1/8" NPTF female	1/2" to 20" male	5/16" ID	90 PSI (6.2 bar)

- Standard Equipment**
- Bant-A-Matic Series (Clutch-Type)
    - 42123-1 Tapping Head Attachment
    - 37431-2 No. 0-No. 10 Cap. Rubber Flex Collet Insert
    - 37431-3 No. 10-1/4" Cap. Rubber Flex Collet Insert
    - 47884 Pneumatic Controls Interface Kits\*
    - Necessary Wrenches

- Par-A-Matic Series (Jaw-Type)
  - 34000-1 Tapping Head Attachment
  - 31432 No. 10-5/16" Cap. Tap Chuck (See Model Identification Chart on page 20)
  - 31427 No. 1/4 Cap. Tap Chuck (See Model Identification Chart on page 20)
  - 32060 No. 1/4-5/8" Cap. Tap Chuck (See Model Identification Chart on page 20)
  - 47884 Pneumatic Controls Interface Kits\*
  - Necessary Wrenches

- Par-A-Matic Series (Clutch-Type)
  - 38021-4 Tapping Head Attachment
  - 38036 No. 0-1/4" Cap. Rubber Flex Collet Insert
  - 38036-1 No. 1/4-1/2" Cap. Rubber Flex Collet Insert
  - 47884 Pneumatic Controls Interface Kits\*
  - Necessary Wrenches

### Accessories at Extra Cost

- Bant-A-Matic Series
  - 40301-( ) Hydraulic Checks
  - 39486 Flange Bracket
  - 39485-1 Foot Bracket
  - 45053 H.D. Foot Bracket
  - 36042 Split-Block Clamp
  - Service Kits

- Par-A-Matic Series
  - 40591-( ) Hydraulic Checks
  - 38877 Flange Bracket
  - 38875-1 Foot Bracket
  - 45055 H.D. Foot Bracket
  - 35283 Split-Block Clamp
  - Service Kits

\*Contains (2) 6045 90° street elbows and (2) 9600 pilot bleeder valves.

# Tappers

## Pneumatic Lead Screw Tappers

The Lead Screw Tapper is designed for precision hole tapping in medium and high-production machining applications. The tool is air operated and is fully automatic, with a built-in pressure-operated valve, manual controls and remote control ports for starting and retracting. Installation is easy, with only simple pneumatic circuitry required. It can be used individually or in conjunction with other pneumatic and electric self-feed tools and machine components.

### Features

- Repeatable tapping depth accuracy of  $\pm 0.005"$  (.127 mm).
- Stroke length is fully adjustable from 3/16" (4.8 mm) minimum to 2.0" (50.8 mm) maximum for use in a wide range of setups.
- A built-in "no-hole" sensing system prolongs tap life by automatically retracting the spindle when a pilot hole is missing or when excessive misalignment exists.
- Modular tool design enables easy servicing of air motor and gearing, and offers convenient, economical speed and lead screw conversions as job requirements change.
- Compact size requires less machine space for increased design flexibility.
- Fixed-position foot mounting requires no additional mounting hardware while providing added rigidity.
- A wide selection of models is available for both American and metric threads.
- Twin and multi-spindle tapping heads are available for close-center machining requirements.

## 2200 Series

1/2" (M12) Capacity, Steel  
.62 HP (.47 kW)

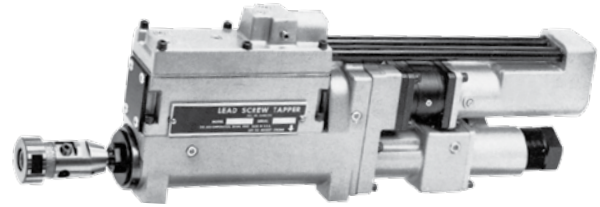

8655-B24-A

Example of product identification

8 6 5 5 — B 2 4 — A

Free Speed  
5 = 175 rpm  
6 = 325 rpm  
7 = 600 rpm  
8 = 1300 rpm  
9 = 2400 rpm

Thread Pitch or  
Lead Indicator  
Tool Generation

Model	Free Speed rpm	NOMINAL TAP CAPACITIES		American Thread Pitch (T.P.I.)	Lead Screw and Nut Assembly	Air Cons.† at Working Speed ft <sup>3</sup> /cycle (L/cycle)	Standard Chuck Capacity in (mm)
		Steel SAE 1213	Aluminum 2024-T4				
8655-B11-A	175	3/8" to 1/2 (M10 to M12)	7/16 to 5/8 (M10 to M16)	11	45453-11		
8655-B12-A	175	3/8" to 1/2 (M10 to M12)	7/16 to 5/8 (M10 to M16)	12	45453-12		
8655-B13-A	175	3/8" to 1/2 (M10 to M12)	7/16 to 5/8 (M10 to M16)	13	45453-13		
8655-B14-A	175	3/8" to 1/2 (M10 to M12)	7/16 to 5/8 (M10 to M16)	14	45453-14		
8655-B16-A	175	3/8" to 1/2 (M10 to M12)	7/16 to 5/8 (M10 to M16)	16	45453-16		
8655-B18-A	175	3/8" to 1/2 (M10 to M12)	7/16 to 5/8 (M10 to M16)	18	45453-18		
8655-B20-A	175	3/8" to 1/2 (M10 to M12)	7/16 to 5/8 (M10 to M16)	20	45453-20	3.0 (85)	No. 0 to 1/2" (M4.5 to M12)
8655-B24-A	175	3/8" to 1/2 (M10 to M12)	7/16 to 5/8 (M10 to M16)	24	45453-24		
8655-B27-A	175	3/8" to 1/2 (M10 to M12)	7/16 to 5/8 (M10 to M16)	27	45453-27		
8655-B28-A	175	3/8" to 1/2 (M10 to M12)	7/16 to 5/8 (M10 to M16)	28	45453-28		
8655-B32-A	175	3/8" to 1/2 (M10 to M12)	7/16 to 5/8 (M10 to M16)	32	45453-32		
8655-B36-A	175	3/8" to 1/2 (M10 to M12)	7/16 to 5/8 (M10 to M16)	36	45453-36		
8655-B40-A	175	3/8" to 1/2 (M10 to M12)	7/16 to 5/8 (M10 to M16)	40	45453-40		
8655-B44-A	175	3/8" to 1/2 (M10 to M12)	7/16 to 5/8 (M10 to M16)	44	45453-44		
8655-B48-A	175	3/8" to 1/2 (M10 to M12)	7/16 to 5/8 (M10 to M16)	48	45453-48		
8655-B56-A	175	3/8" to 1/2 (M10 to M12)	7/16 to 5/8 (M10 to M16)	56	45453-56		
8656-B11-A	325	1/4 to 7/16 (M6 to M10)	5/16 to 1/2 (M8 to M12)	11	45453-11		
8656-B12-A	325	1/4 to 7/16 (M6 to M10)	5/16 to 1/2 (M8 to M12)	12	45453-12		
8656-B13-A	325	1/4 to 7/16 (M6 to M10)	5/16 to 1/2 (M8 to M12)	13	45453-13		
8656-B14-A	325	1/4 to 7/16 (M6 to M10)	5/16 to 1/2 (M8 to M12)	14	45453-14		
8656-B16-A	325	1/4 to 7/16 (M6 to M10)	5/16 to 1/2 (M8 to M12)	16	45453-16		
8656-B18-A	325	1/4 to 7/16 (M6 to M10)	5/16 to 1/2 (M8 to M12)	18	45453-18		
8656-B20-A	325	1/4 to 7/16 (M6 to M10)	5/16 to 1/2 (M8 to M12)	20	45453-20	3.0 (85)	No. 0 to 1/2" (M4.5 to M12)
8656-B24-A	325	1/4 to 7/16 (M6 to M10)	5/16 to 1/2 (M8 to M12)	24	45453-24		
8656-B27-A	325	1/4 to 7/16 (M6 to M10)	5/16 to 1/2 (M8 to M12)	27	45453-27		
8656-B28-A	325	1/4 to 7/16 (M6 to M10)	5/16 to 1/2 (M8 to M12)	28	45453-28		
8656-B32-A	325	1/4 to 7/16 (M6 to M10)	5/16 to 1/2 (M8 to M12)	32	45453-32		
8656-B36-A	325	1/4 to 7/16 (M6 to M10)	5/16 to 1/2 (M8 to M12)	36	45453-36		
8656-B40-A	325	1/4 to 7/16 (M6 to M10)	5/16 to 1/2 (M8 to M12)	40	45453-40		
8656-B44-A	325	1/4 to 7/16 (M6 to M10)	5/16 to 1/2 (M8 to M12)	44	45453-44		
8656-B48-A	325	1/4 to 7/16 (M6 to M10)	5/16 to 1/2 (M8 to M12)	48	45453-48		
8656-B56-A	325	1/4 to 7/16 (M6 to M10)	5/16 to 1/2 (M8 to M12)	56	45453-56		

(continued next page)

Model	Free Speed rpm	NOMINAL TAP CAPACITIES		American Thread Pitch (T.P.I.)	Lead Screw and Nut Assembly	Air Cons. ‡ at Working Speed ft <sup>3</sup> /cycle (L/cycle)	Standard Chuck Capacity in (mm)
		Steel SAE 1 2 1 3	Aluminum 2024-T4				
8657-B11-A	600	No. 8 to 1/4 (M4 to M6)	1/4 to 5/16 (M6 to M8)	11	45453-11		
8657-B12-A	600	No. 8 to 1/4 (M4 to M6)	1/4 to 5/16 (M6 to M8)	12	45453-12		
8657-B13-A	600	No. 8 to 1/4 (M4 to M6)	1/4 to 5/16 (M6 to M8)	13	45453-13		
8657-B14-A	600	No. 8 to 1/4 (M4 to M6)	1/4 to 5/16 (M6 to M8)	14	45453-14		
8657-B16-A	600	No. 8 to 1/4 (M4 to M6)	1/4 to 5/16 (M6 to M8)	16	45453-16		
8657-B18-A	600	No. 8 to 1/4 (M4 to M6)	1/4 to 5/16 (M6 to M8)	18	45453-18		
8657-B20-A	600	No. 8 to 1/4 (M4 to M6)	1/4 to 5/16 (M6 to M8)	20	45453-20	3.0 (85)	No. 0 to 1/2" (M4.5 to M12)
8657-B24-A	600	No. 8 to 1/4 (M4 to M6)	1/4 to 5/16 (M6 to M8)	24	45453-24		
8657-B27-A	600	No. 8 to 1/4 (M4 to M6)	1/4 to 5/16 (M6 to M8)	27	45453-27		
8657-B28-A	600	No. 8 to 1/4 (M4 to M6)	1/4 to 5/16 (M6 to M8)	28	45453-28		
8657-B32-A	600	No. 8 to 1/4 (M4 to M6)	1/4 to 5/16 (M6 to M8)	32	45453-32		
8657-B36-A	600	No. 8 to 1/4 (M4 to M6)	1/4 to 5/16 (M6 to M8)	36	45453-36		
8657-B40-A	600	No. 8 to 1/4 (M4 to M6)	1/4 to 5/16 (M6 to M8)	40	45453-40		
8657-B44-A	600	No. 8 to 1/4 (M4 to M6)	1/4 to 5/16 (M6 to M8)	44	45453-44		
8657-B48-A	600	No. 8 to 1/4 (M4 to M6)	1/4 to 5/16 (M6 to M8)	48	45453-48		
8657-B56-A	600	No. 8 to 1/4 (M4 to M6)	1/4 to 5/16 (M6 to M8)	56	45453-56		
<hr/>							
8658-B13-A	1300	No. 2 to No. 10 (M2 to M5)	No. 2 to 5/16 (M2 to M8)	13	45453-13		
8658-B14-A	1300	No. 2 to No. 10 (M2 to M5)	No. 2 to 5/16 (M2 to M8)	14	45453-14		
8658-B16-A	1300	No. 2 to No. 10 (M2 to M5)	No. 2 to 5/16 (M2 to M8)	16	45453-16		
8658-B18-A	1300	No. 2 to No. 10 (M2 to M5)	No. 2 to 5/16 (M2 to M8)	18	45453-18		
8658-B20-A	1300	No. 2 to No. 10 (M2 to M5)	No. 2 to 5/16 (M2 to M8)	20	45453-20	3.0 (85)	No. 0 to 1/2" (M4.5 to M12)
8658-B24-A	1300	No. 2 to No. 10 (M2 to M5)	No. 2 to 5/16 (M2 to M8)	24	45453-24		
8658-B27-A	1300	No. 2 to No. 10 (M2 to M5)	No. 2 to 5/16 (M2 to M8)	27	45453-27		
8658-B28-A	1300	No. 2 to No. 10 (M2 to M5)	No. 2 to 5/16 (M2 to M8)	28	45453-28		
8658-B32-A	1300	No. 2 to No. 10 (M2 to M5)	No. 2 to 5/16 (M2 to M8)	32	45453-32		
8658-B36-A	1300	No. 2 to No. 10 (M2 to M5)	No. 2 to 5/16 (M2 to M8)	36	45453-36		
8658-B40-A	1300	No. 2 to No. 10 (M2 to M5)	No. 2 to 5/16 (M2 to M8)	40	45453-40		
8658-B44-A	1300	No. 2 to No. 10 (M2 to M5)	No. 2 to 5/16 (M2 to M8)	44	45453-44		
8658-B48-A	1300	No. 2 to No. 10 (M2 to M5)	No. 2 to 5/16 (M2 to M8)	48	45453-48		
8658-B56-A	1300	No. 2 to No. 10 (M2 to M5)	No. 2 to 5/16 (M2 to M8)	56	45453-56		
<hr/>							
8659-B24-A	2400	No. 2 to No. 8 (M2 to M4)	No. 2 to No. 10 (M2 to M5)	24	45453-24		
8659-B27-A	2400	No. 2 to No. 8 (M2 to M4)	No. 2 to No. 10 (M2 to M5)	27	45453-27		
8659-B28-A	2400	No. 2 to No. 8 (M2 to M4)	No. 2 to No. 10 (M2 to M5)	28	45453-28		
8659-B32-A	2400	No. 2 to No. 8 (M2 to M4)	No. 2 to No. 10 (M2 to M5)	32	45453-32		
8659-B36-A	2400	No. 2 to No. 8 (M2 to M4)	No. 2 to No. 10 (M2 to M5)	36	45453-36		
8659-B40-A	2400	No. 2 to No. 8 (M2 to M4)	No. 2 to No. 10 (M2 to M5)	40	45453-40		
8659-B44-A	2400	No. 2 to No. 8 (M2 to M4)	No. 2 to No. 10 (M2 to M5)	44	45453-44		
8659-B48-A	2400	No. 2 to No. 8 (M2 to M4)	No. 2 to No. 10 (M2 to M5)	48	45453-48		
8659-B56-A	2400	No. 2 to No. 8 (M2 to M4)	No. 2 to No. 10 (M2 to M5)	56	45453-56		

Metric pitches available, Special Tappers available, featuring high duty cycle, twin and multi-spindle heads, and left hand threads. Consult factory.

+Consumption in cubic feet during a typical 6 second cycle time. NOTE: Performance data given at 90 PSI (6.2 bar) air pressure.

Air Inlet	Control Ports	Spindle Thread	Recommended Hose Size	Recommended Operating Pressure
3/8" NPT (female)	1/8" NPT (female)	No.1 Morse Taper (female)	1/2" ID	90 PSI (6.2 bar)

**Standard Equipment**

- 41376 Tap Chuck, No. 0-1/2" (M4.5 - M12) Cap.
- Necessary wrenches

**Accessories at Extra Cost**

- 44889 Floating Tap Chuck, No. 0-5/8" (M1.6 - M16) Cap.
- 44890-( ) Collets for 44889 Chuck

**44889 Floating Tap Chuck**



Provides parallel float up to 0.030" (0.76 mm) to ensure the tap being driven aligns properly with the drilled hole. Order the desired size 44890-( ) Collet separately from the chart at the right.

American Hand Tap Size	Metric Hand Tap Size	Collet ID in (mm)	Collet No.
No. 0 - No. 6	M1.6 - M6	.141" (3.58)	44890-1
No. 8	M4	.168" (4.27)	44890-2
No. 10	M4.5 - M5	.194" (4.93)	44890-3
No. 12	—	.220" (5.59)	44890-4
No. 14 & 1/4"	M6	.255" (6.48)	44890-5
5/16"	M7 - M8	.318" (8.08)	44890-6
3/8"	—	.381" (9.68)	44890-7
7/16"	M10	.323" (8.20)	44890-8
1/2"	M12	.367" (9.32)	44890-9
9/16"	M14	.429" (10.90)	44890-10
5/8"	M16	.480" (12.19)	44890-11
1/8" Small Shank Pipe	—	.313" (7.95)	44890-12
1/8" Large Shank Pipe	—	.438" (11.12)	44890-13

# Spindle Accessories

## Drill Chucks

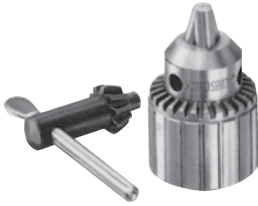

Chuck No.	Capacity in (mm)	Thread Size	Body Length		*Cutting Tool Penetration	Outside Diameter	Chuck Key No.
			Jaws Closed	Jaws Open			
33906	0-1/4" (0-6.4)	1/2-20 R.H.	2.190 (55.6)	1.750 (44.5)	11/16 (17.5)	1.320 (33.5)	30209-K
47341	0-3/8" (0-9.5)	3/8-24 R.H.	2.47 (63)	1.930 (49)	13/16 (20.6)	1.420 (36)	30510-K
45176	0-3/8" (0-9.5)	5/8-16 R.H.	3.060 (78)	2.310 (58.7)	61/64 (24)	1.790 (45.5)	30016-K
33907	0-3/8" (0-9.5)	1/2-20 R.H.	2.500 (63.5)	1.906 (48.4)	13/16 (20.6)	1.437 (36)	30510-K
30018	5/64"-1/2" (2-13)	1/2-20 R.H.	3.090 (78.5)	2.420 (61.5)	1-9/64 (29)	1.790 (45.5)	30016-K
45177	3/16"-3/4" (4.8-19)	5/8-16 R.H.	4.120 (104.6)	3.190 (81)	1-17/32 (39)	2.550 (64.8)	45177-K
46977	5/64"-1/2" (2-13)	#33 Jacobs	3.010 (76.4)	2.51 (63.4)	1-17/32 (29)	2.550 (45.5)	30016-K

\* Cutting Tool Penetration in chuck varies with Cutter Shank diameter.

## Taper Shank Adapters



Taper Shank Adapter No.	Morse Taper	Thread Size	Length	Outside Diameter	For Use On
35211	1	1/2-20 female	3.5" (89 mm)	1.0 (25.4)	Bant-A-Matic, Par-A-Matic
31394	2	1/2-20 female	4.0" (101.5 mm)	1.0 (25.4)	Super Par-A-Matic, 8660 Hi-Thrust
46090	1	5/8-16 female	4.0" (101.5 mm)	1.05 (26.7)	8670 Hi-Thrust
46091	2	5/8-16 female	4.5" (114 mm)	1.17 (29.7)	8670 Hi-Thrust
46987	1	#33 Jacobs Taper	4.0" (101.5 mm)	1.05 (26.7)	Series 34A, 54C & 74B
46986	2	#33 Jacobs Taper	4.5" (114 mm)	1.17 (29.7)	Series 34A, 54C & 74B

Taper Shank Adapters provide secure means of driving larger taper shank drills into harder materials. Sizes are available for all automatic production drills as optional equipment at extra cost.

## Tap Chucks



Chuck No.	Capacity in (mm)	Mounting Style	Length		Cutting Tool Penetration	Outside Diameter	Rubber Flex Insert
			Min	Max			
31427	No. 0—1/4" (M1.6 - M6)	.3675" Dia. (9.3 mm)	2.34 (59.4)	2.51 (63.8)	1.0—1-11/64 (25.4—29.8)	1.07 (27.2)	31437
31432	No. 10—5/16" (M4.5 - M8)	.3675" Dia. (9.3 mm)	2.31 (58.7)	2.52 (64)	1.0—1-11/64 (25.4—29.8)	1.07 (27.2)	31436
41374**	No. 0—1/2" (M4.5 - M12)	#2 Jacobs Taper	2.88 (73.2)	3.13 (79.5)	1-3/32—1-3/8 (27.8—35)	1.46 (37.1)	J440/J443
32060	5/16"—5/8" (M7 - M16)	.3675" Dia. (9.3 mm)	2.86 (72.6)	3.13 (79.5)	1-3/32—1-3/8 (27.8—35)	1.46 (37.1)	32061
32063	5/16"—5/8" (M7 - M16)	#2 Jacobs Taper	2.86 (72.6)	3.13 (79.5)	1-3/32—1-3/8 (27.8—35)	1.46 (37.1)	32061

## Tapping Head Attachment



Tapping Attachment	Capacity	Rubber Flex Inserts	Mounting Thread	Length in (mm)	Cutting Tool Penetration	Outside Diameter
38021-4*	No. 0—1/4" (M1.6 - M6)	38036	1/2-20 R.H.	5.78" (146.8)	1-7/32 (31)	2.75 (69.9)
	1/4"—1/2" (M6 - M12)	38036-1				
42123-1**	No. 0—1/4" (M1.6 - M6)	37431-2 37431-3	2.31 (58.7)	4.25" (108)		1.07 (27.2)

\* Includes 38020-4 Tapping Head and 38020-4 Torque Arm.

\*\* Includes 42106-1 Tapping Head and 37601 Torque Arm. Both attachments also include necessary wrenches.

# Spindle Accessories

## Series 35069-( ) Collets

For use on Series 8660, Par-A-Matic and Super Par-A-Matic Drills.



Collet No.	Size Range - in (mm)	Insert
35069-1	7/32 - 1/4 (5.5 - 6.4)	35263-1
35069-2	1/4 - 9/32 (6.4 - 7.1)	35263-2
35069-3	9/32 - 5/16 (7.1 - 7.9)	35263-3
35069-4	5/16 - 11/32 (7.9 - 8.7)	35263-4
35069-5	11/32 - 3/8 (8.7 - 9.5)	35263-5
35069-6	3/8 - 13/32 (9.5 - 10.3)	35263-6
35069-7	13/32 - 7/16 (10.3 - 11.1)	35263-7
35069-8	7/16 - 15/32 (11.1 - 11.9)	35263-8
35069-9	15/32 - 1/2 (11.9 - 12.7)	35263-9
35069-10	1/2 - 17/32 (12.7 - 13.5)	35263-10
35069-11	17/32 - 9/16 (13.5 - 14.3)	35263-11

- Sub-Assemblies
- 35070 Body
  - 35263-( ) Insert
- Specifications
- Length: 3-1/4" (82.5 mm)
  - Thread: 1/2-20 female
  - Outside Dia.: 1-3/4" (44.5 mm)
  - Approx. Tooling Penetration: 1-3/4" (44.5 mm)

## Series 35074-( ) Collets

For use on Series 8660, Par-A-Matic and Super Par-A-Matic Drills.



Collet No.	Size Range - in (mm)	Insert
35074-1	7/32 - 1/4 (5.5 - 6.4)	35264-1
35074-2	1/4 - 9/32 (6.4 - 7.1)	35264-2
35074-3	9/32 - 5/16 (7.1 - 7.9)	35264-3
35074-4	5/16 - 11/32 (7.9 - 8.7)	35264-4
35074-5	11/32 - 3/8 (8.7 - 9.5)	35264-5
35074-6	3/8 - 13/32 (9.5 - 10.3)	35264-6
35074-7	13/32 - 7/16 (10.3 - 11.1)	35264-7
35074-8	7/16 - 15/32 (11.1 - 11.9)	35264-8
35074-9	15/32 - 1/2 (11.9 - 12.7)	35264-9
35074-10	1/2 - 17/32 (12.7 - 13.5)	35264-10
35074-11	17/32 - 9/16 (13.5 - 14.3)	35264-11
35074-12	9/16 - 19/32 (14.3 - 15.1)	35264-12
35074-13	19/32 - 5/8 (15.1 - 15.9)	35264-13
35074-14	5/8 - 21/32 (15.9 - 16.6)	35264-14
35074-17	23/32 - 3/4 (18.2 - 19.0)	35264-17

- Sub-Assemblies
- 35075 Body
  - 35264-( ) Insert
- Specifications
- Length: 3-1/4" (82.5 mm)
  - Thread: 1/2-20 female
  - Outside Dia.: 2-1/32" (51.6 mm)
  - Approx. Tooling Penetration: 1-7/8" (47.6 mm)

## Series 35079-( ) Collets

For use on Bant-A-Matic, Par-A-Matic and Super Par-A-Matic Drills.



Collet No.	Size Range - in (mm)	Insert
35079-1	3/32 - 1/8 (2.4 - 3.2)	32968-1
35079-2	1/8 - 5/32 (3.2 - 4.0)	32968-2
35079-3	5/32 - 3/16 (4.0 - 4.8)	32968-3
35079-4	3/16 - 7/32 (4.8 - 5.5)	32968-4
35079-5	7/32 - 1/4 (5.5 - 6.4)	32968-5
35079-6	1/4 - 9/32 (6.4 - 7.1)	32968-6
35079-7	9/32 - 5/16 (7.1 - 7.9)	32968-7
35079-8	5/16 - 11/32 (7.9 - 8.7)	32968-8
35079-9	11/32 - 3/8 (8.7 - 9.5)	32968-9

- Sub-Assemblies
- 35080 Body
  - 32968-( ) Insert
- Specifications
- Length: 2-11/16" (68.3 mm)
  - Thread: 1/2-20 female
  - Outside Dia.: 1-7/16" (36.5 mm)
  - Approx. Tooling Penetration: 1-3/8" (34.9 mm)

## Series 39959-( ) Collets

For use on Par-A-Matic Offset Drills.



Collet No.	Size Range - in (mm)	Insert
39959-2	.094 - .177 (2.4 - 4.5)	37431-2
39959-3	.177 - .256 (4.5 - 6.5)	37431-3

- Sub-Assemblies
- 39958 Body & Nut
  - 37431-( ) Insert
- Specifications
- Length: 1-15/16" (49.2 mm)
  - Thread: 3/8-24 female
  - Outside Dia.: 3/4" (19 mm)
  - Approx. Tooling Penetration: 1-5/16" (33.3 mm)

## Series 41758-( ) Collets

For use on Series 8660, Par-A-Matic, Super Par-A-Matic and Bant-A-Matic Drills.



Collet No.	Size Range - in (mm)	Insert
41758-1	1/64 - 3/64 (.40 - 1.2)	31812-1
41758-2	3/64 - 5/64 (1.2 - 2.0)	31812-2
41758-3	5/64 - 3/32 (2.0 - 2.4)	31812-3
41758-4	3/32 - 1/8 (2.4 - 3.2)	31812-4
41758-5	1/8 - 5/32 (3.2 - 4.0)	31812-5
41758 6	5/32 - 3/16 (4.0 - 4.8)	31812-6
41758-7	3/16 - 7/32 (4.8 - 5.5)	31812-7
41758-8	7/32 - 1/4 (5.5 - 6.4)	31812-8

- Sub-Assemblies
- 41756 Body
  - 32541 Nut
  - 31812-( ) Insert
- Specifications
- Length: 2-9/16" (65.1 mm)
  - Thread: 1/2-20 female
  - Outside Dia.: 3/4" (19 mm)
  - Approx. Tooling Penetration: 1-5/16" (33.3 mm)

## SERIES 46093-( ) & 48175-( ) COLLETS

Series 8670 Hi-Thrust Drills use 46093-( ).



48175      46093

Collet No.	Size Range - in (mm)	Insert	
46093-1	48175-1	7/32 - 1/4 (5.5 - 6.4)	35264-1
46093-2	48175-2	1/4 - 9/32 (6.4 - 7.1)	35264-2
46093-3	48175-3	9/32 - 5/16 (7.1 - 7.9)	35264-3
46093-4	48175-4	5/16 - 11/32 (7.9 - 8.7)	35264-4
46093-5	48175-5	11/32 - 3/8 (8.7 - 9.5)	35264-5
46093-6	48175-6	3/8 - 13/32 (9.5 - 10.3)	35264-6
46093-7	48175-7	13/32 - 7/16 (10.3 - 11.1)	35264-7
46093-8	48175-8	7/16 - 15/32 (11.1 - 11.9)	35264-8
46093-9	48175-9	15/32 - 1/2 (11.9 - 12.7)	35264-9
46093-10	48175-10	1/2 - 17/32 (12.7 - 13.5)	35264-10
46093-11	48175-11	17/32 - 9/16 (13.5 - 14.3)	35264-11
46093-12	48175-12	9/16 - 19/32 (14.3 - 15.1)	35264-12
46093-13	48175-13	19/32 - 5/8 (15.1 - 15.9)	35264-13
46093-14	48175-14	5/8 - 21/32 (15.9 - 16.6)	35264-14
46093-15	48175-15	21/32 - 11/16 (16.6 - 17.4)	35264-15
46093-16	48175-16	11/16 - 23/32 (17.4 - 18.2)	35264-16
46093-17	48175-17	23/32 - 3/4 (18.2 - 19.0)	35264-17

- Series 46093
- Sub-Assemblies
- 46093 Body
  - 35264-( ) Insert

- Series 46093 Specifications
- Length: 3.0" (76.2 mm)
  - Thread: 5/8-16 female
  - Outside Dia.: 1-5/8" (41.3 mm)
  - Approx. Tooling Penetration: 1-7/8" (47.6 mm)

- Series 48175
- Sub-Assemblies
- 48091 Body
  - 35264-( ) Insert

- Series 48175 Specifications
- Length: 3-5/16" (84 mm)
  - Taper: No. 33 Jacobs
  - Outside Dia.: 1-3/4" (44 mm)
  - Approx. Tooling Penetration: 1-7/8" (47.6 mm)

# Spindle Accessories

## Automation Tools Standard Twin Drill/Twin Tap Heads

For single spindle drills already in operation, twin drill Head Attachments can be ordered separately which fit directly to Bant-A-Matic, Par-A-Matic, Super Par-A-Matic, and Series 3 Electra-Feed Drills.

Twin Drill Heads have a 1:1 gear ratio and are rated for 5,000 rpm maximum. Heads come complete with necessary wrenches. Collets must be ordered separately.

5/32" (4.0 mm) Collet Capacity  
**Model 46394**  
 for Bant-A-Matic Drills



1/4" (6.5 mm) Collet Capacity  
**Model 46023**  
 for Par-A-Matic Drills  
**Model 47489**  
 for Super Par-A-Matic Drills



3/8" (9.5 mm) Collet Capacity  
**Model 46063**  
 for Super Par-A-Matic Drills  
**Model 47276**  
 for Series 34A, 54C & 74B Electra-Feed Drills

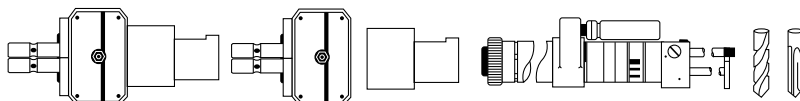

Complete Head Assembly	Head Assembly	Adapter Assembly	Used On	Used For	Adj. Spindle Center Distances, in		Series Part Number	Collet Bore, in		Max Tap Size
					Min	Max		Min	Max	
46394	48057-1	48056-1	Bant-A-Matic	Drilling	.375	2.125	47368-()	.039	.157	
48060-1	48057-1	48058-1	Bant-A-Matic	Tapping	.375	2.125	47368-()			#6
46023	47980	47283	Par-A-Matic	Drilling	.500	2.500	45998-()	.039	.256	
48055	47980	47982	Par-A-Matic	Tapping	.500	2.500	45998-()			1/4"
46063	47768	47767	S. Par-A-Matic	Drilling	.750	3.750	46033-()	.079	.375	
47288	47768	47282	S. Par-A-Matic	Tapping	.750	3.750	46033-()			5/16"
47489	47980	47490	S. Par-A-Matic	Drilling	.500	2.500	45998-()	.039	.256	
48061-1	48057-1	48059-1	Lead Screw Tapper	Tapping	.375	2.125	47368-()			#6
48054	47980	47981	Lead Screw Tapper	Tapping	.500	2.500	45998-()			1/4"
47277	47768	47785	Lead Screw Tapper	Tapping	.750	3.750	46033-()			5/16"

NOTE: Drill bits should always be operated in drill bushings for proper support and alignment.



# Spindle Accessories

## Multi-Spindle Drilling/Tapping Heads

In addition to the Twin Spindle drill and tapping heads shown on page 26, there are several other configurations available. Each configuration is offered in a head size (type) that matches the size and duty of a particular self-feed tool.

**TWIN SPINDLE  
EXTRA REACH  
ADJUSTABLE**

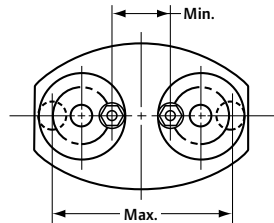

Type	Max	Drill	CENTERS		Used With	Collets Used
			Min - in (mm)	Max - in (mm)		
400	5/32	(4.0)	.750 (19.0)	2.500 (63.5)	A	47368 - ( )
650	1/4	(6.5)	1.000 (12.7)	3.000 (76.2)	B, F, G	45998 - ( )
950	3/8	(9.5)	1.500 (38.1)	4.500 (114.3)	C, D, E, F, G	46033 - ( )

**THREE SPINDLE  
IN LINE  
ADJUSTABLE**

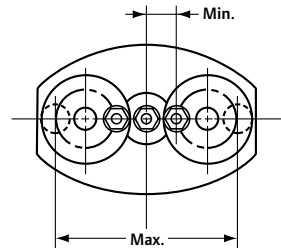

Type	Max	Drill	CENTERS		Used With	Collets Used
			Min - in (mm)	Max - in (mm)		
400	5/32	(4.0)	.375 (9.5)	1.250 (31.7)	A	47368 - ( )
650	1/4	(6.5)	.500 (12.7)	1.500 (38.1)	B, F, G	45998 - ( )
950	3/8	(9.5)	.750 (19.0)	2.250 (57.1)	C, D, E	46033 - ( )

**THREE SPINDLE  
ADJUSTABLE**

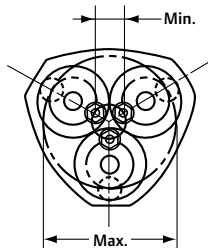

Type	Max	Drill	CENTERS		Used With	Collets Used
			Min - in (mm)	Max - in (mm)		
400	5/32	(4.0)	.565 (14.3)	2.320 (58.9)	A	47368 - ( )
650	1/4	(6.5)	.735 (18.7)	2.730 (69.3)	B, F, G.	45998 - ( )
950	3/8	(9.5)	1.100 (27.9)	4.100 (104.1)	C, D, E,	46033 - ( )

**FOUR SPINDLE  
ADJUSTABLE**

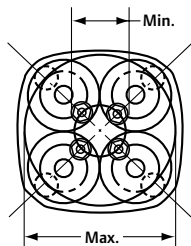

Type	Max	Drill	CENTERS		Used With	Collets Used
			Min - in (mm)	Max - in (mm)		
400	5/32	(4.0)	.890 (22.6)	2.645 (67.2)	A	47368 - ( )
650	1/4	(6.5)	1.125 (28.6)	3.120 (79.2)	B, F, G.	45998 - ( )
950	3/8	(9.5)	1.680 (42.7)	4.680 (118.9)	C, D, E,	46033 - ( )

**FIXED CENTER  
NON-ADJUSTABLE**

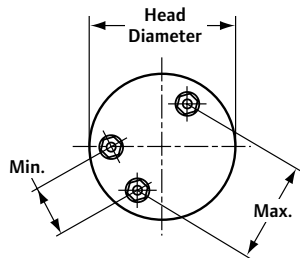

Type	Max	Drill	CENTERS		Used With	Collets Used
			Min - in (mm)	Max - in (mm)		
400	5/32	(4.0)	.375 (9.5)	2.125 (54.0)	A	47368 - ( )
650	1/4	(6.5)	.500 (12.7)	2.500 (63.5)	B, F, G.	45998 - ( )
950	3/8	(9.5)	.750 (19.0)	3.750 (95.0)	C, D, E,	46033 - ( )

USED WITH: A=Bant-A-Matic B=Par-A-Matic C=Super Par-A-Matic D=8660 E=8670  
F=FE034A G=FE054C H=FE074A

For assistance with application, dimensions, price and delivery - consult factory.

# Spindle Accessories

## Twin Drill Collets



Bore Diameter +.000 -.0035	DRILL SIZES			46394 HEAD (Bant-A-Matic)	46023 HEAD (Par-A-Matic) 47489 HEAD	46063 HEAD 47276 HEAD (Super Par-A-Matic)
	inch	no.	mm			
.039"		61	1.0	47368-1	45998-1	
.043"		57	1.1	47368-2	45998-2	
.047"	3/64	56	1.2	47368-3	45998-3	
.052"		55	1.3	47368-4	45998-4	
.055"		54	1.4	47368-5	45998-5	
.059"		53	1.5	47368-6	45998-6	
.063"	1/16	52	1.6	47368-7	45998-7	
.067"		51	1.7	47368-8	45998-8	
.071"		50	1.8	47368-9	45998-9	
.075"		48	1.9	47368-10	45998-10	
.079"	5/64	47	2.0	47368-11	45998-11	46033-1
.083"		45	2.1	47368-12	45998-12	46033-2
.087"		44	2.2	47368-13	45998-13	46033-3
.091"		43	2.3	47368-14	45998-14	46033-4
.094"	3/32	42	2.4	47368-15	45998-15	46033-5
.098"		40	2.5	47368-16	45998-16	46033-6
.102"		38	2.6	47368-17	45998-17	46033-7
.106"		36	2.7	47368-18	45998-18	46033-8
.110"	7/64	35	2.8	47368-19	45998-19	46033-9
.114"		33	2.9	47368-20	45998-20	46033-10
.118"		32	3.0	47368-21	45998-21	46033-11
.122"		31	3.1	47368-22	45998-22	46033-12
.126"	1/8	—	3.2	47368-23	45998-23	46033-13
.130"		30	3.3	47368-24	45998-24	46033-14
.134"		29	3.4	47368-25	45998-25	46033-15
.138"		—	3.5	47368-26	45998-26	46033-16
.142"	9/64	28	3.6	47368-27	45998-27	46033-17
.146"		26	3.7	47368-28	45998-28	46033-18
.150"		25	3.8	47368-29	45998-29	46033-19
.154"		23	3.9	47368-30	45998-30	46033-20
.157"	5/32	22	4.0	47368-31	45998-31	46033-21
.161"		20	4.1		45998-32	46033-22
.165"		19	4.2		45998-33	46033-23
.169"		18	4.3		45998-34	46033-24
.173"	11/64	17	4.4		45998-35	46033-25
.177"		16	4.5		45998-36	46033-26
.181"		14	4.6		45998-37	48033-27
.185"		13	4.7		45998-38	46033-28
.189"	3/16	12	4.8		45998-39	46033-29
.193"		10	4.9		45998-40	46033-30
.197"		9	5.0		45998-41	46033-31
.201"		7	5.1		45998-42	46033-32
.205"	13/64	5	5.2		45998-43	46033-33

Bore Diameter +.000 -.0035	DRILL SIZES			46023 HEAD (Par-A-Matic) 47489 HEAD	46063 HEAD 47276 HEAD (Super Par-A-Matic)
	inch	no.	mm		
.209"		4	5.3	45998-44	46033-34
.213"		3	5.4	45998-45	46033-35
.216"		—	5.5	45998-46	46033-36
.220"	7/32	2	5.6	45998-47	46033-37
.224"		—	5.7	45998-48	46033-38
.228"		1	5.8	45998-49	46033-39
.232"		—	5.9	45998-50	46033-40
.236"	15/64	A	6.0	45998-51	46033-41
.240"		B	6.1	45998-52	46033-42
.244"		C	6.2	45998-53	46033-43
.248"		D	6.3	45998-54	46033-44
.252"	1/4	E	6.4	45998-55	46033-45
.256"		F	6.5	45998-56	46033-46
.260"		G	6.6		46033-47
.264"	17/64	—	6.7		46033-48
.268"		H	6.8		46033-49
.272"		I	6.9		46033-50
.276"		J	7.0		46033-51
.280"	9/32	K	7.1		46033-52
.283"		—	7.2		46033-53
.287"		—	7.3		46033-54
.291"		L	7.4		46033-55
.295"		M	7.5		46033-56
.299"	19/64	—	7.6		46033-57
.303"		N	7.7		46033-58
.307"		—	7.8		46033-59
.311"	5/16	—	7.9		46033-60
.315"		O	8.0		46033-61
.319"		—	8.1		46033-62
.323"		P	8.2		46033-63
.327"	21/64	—	8.3		46033-64
.331"		Q	8.4		46033-65
.335"		—	8.5		46033-66
.339"		R	8.6		46033-67
.342"	11/32	—	8.7		46033-68
.346"		—	8.8		46033-69
.350"		S	8.9		46033-70
.354"		—	9.0		46033-71
.358"	23/64	T	9.1		46033-72
.362"		—	9.2		46033-73
.366"		—	9.3		46033-74
.370"		U	9.4		46033-75
.375"	3/8	—	9.5		46033-76

Tapping Head Number	#0 - #6	#8	#10	#12	1/4"	5/16"
48060-1	47368-27	NA	NA	NA	NA	NA
48061-1	47368-27	NA	NA	NA	NA	NA
48054	45998-27	45998-34	45998-41	45998-47	45998-56	NA
48055	45998-27	45998-34	45998-41	45998-47	45998-56	NA
47277	46033-17	46033-24	46033-31	46033-37	46033-46	46033-62
47288	46033-17	46033-24	46033-31	46033-37	46033-46	46033-62
47908	46033-17	46033-24	46033-31	46033-37	46033-46	46033-62

# Controll Accessories

## Hydraulic Check Units

For added tool versatility and performance, Hydraulic Check Units can be used to provide positive feed rate or breakthrough control. Units are available in 1", 2" and 3" stroke lengths for all electric and pneumatic feed tools. They are easily installed and never need to be refilled. Other benefits include —

- allows rapid advance to the workpiece to minimize cycle time
- fully adjustable settings to achieve optimum chip size
- helps prevent drill bit breakage, drill stalling and heavy burrs

Hydraulic checks are standard equipment on all Hi-Thrust Series Drills, and are available at extra cost for all Bant-A-Matic, Par-A-Matic, Super Par-A-Matic Drills and all Series 34A, 54C and 74B Electra Feed Drills.



Tool Series	1.0" (25mm) Hydraulic Check Assembly*	Stroke Check Only	2.0" (51mm) Hydraulic Check Assembly*	Stroke Check Only	3.0" (76mm) Hydraulic Check Assembly*	Stroke Check Only	Mounting Bracket
Bant-A-Matic	40301-2	38922	40301-3	38922-1	40301-4	38922-2	40298
Par-A-Matic	40591-3	38922	40591-4	38922-1	40591-5	38922-2	40316
Super Par-A-Matic	40591-3	38922	40591-4	38922-1	40591-5	38922-2	40316
8670 Hi-Thrust	—	38922	—	38922-1	—	38922-2	44910

\*Hydraulic Check Assemblies come complete with check and mounting bracket.

## Electronic Interface Kit

120 VAC Kit No. 80183395  
24 VDC Kit No. 80183403

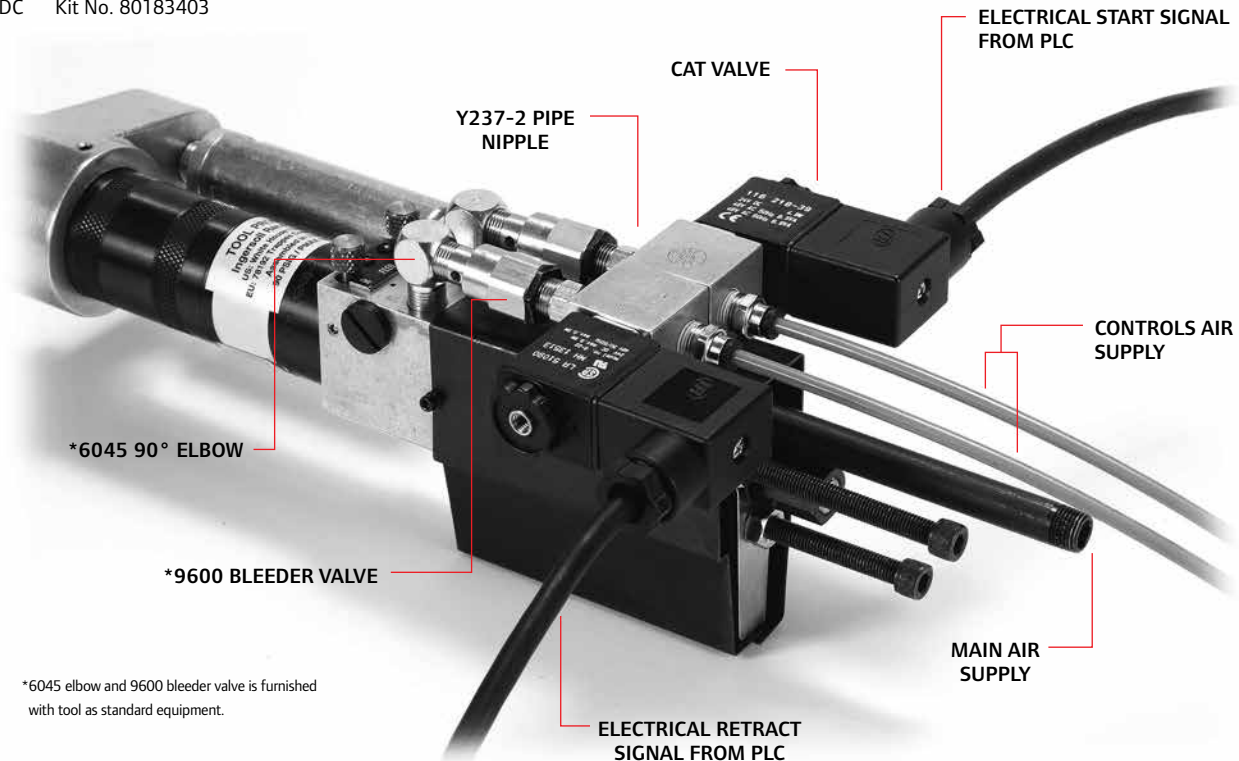

\*6045 elbow and 9600 bleeder valve is furnished with tool as standard equipment.

# Control Accessories

## 41729 Dwell Control Kit

The 41729 Dwell Control Kit is a complete, easily installed control accessory for pneumatic and electric feed drills. It provides an adjustable, precisely timed pause, or dwell, at the end of the forward stroke. The range of the dwell interval, prior to retraction, is from .10 to 10 seconds.

Depth control for automatic feed drills is achieved through the use of a positive-stop adjustment screw. The addition of the dwell control is desirable for countersinking and cleanup applications.

The 41729 Dwell Control Kit may be used on any of the drill models listed in the chart.

TOOL SERIES		
Bant-A-Matic	Par-A-Matic	Super Par-A-Matic
8245	8255	8265
8248	8258	8268
	8266	

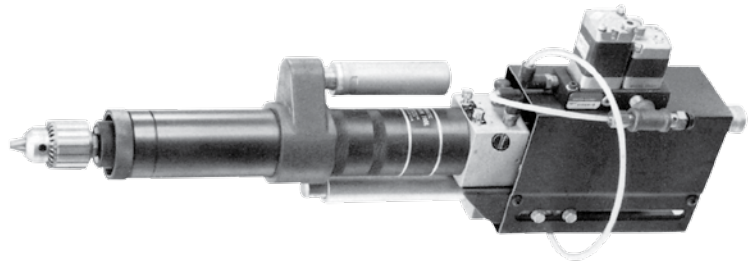

## 41730 Auxiliary Control Kit

The 41730 Auxiliary Control Kit provides increased flexibility to pneumatic and electric automatic feed tools in designing automated machining systems. It can be used to generate a cycle completion signal, for example, or any other desired auxiliary signal.

Each kit is furnished with a miniature, three-way limit valve having a short roller lever and instant tube fittings. Additional limit valves can be installed for other functions.

The 41730 Auxiliary Control Kit may be used on any of the tool models listed in the chart.

TOOL SERIES		
Bant-A-Matic	Par-A-Matic	Super Par-A-Matic
8245	8255	8265
8246	8256	8268
8248	8257	
	8258	
	8266	

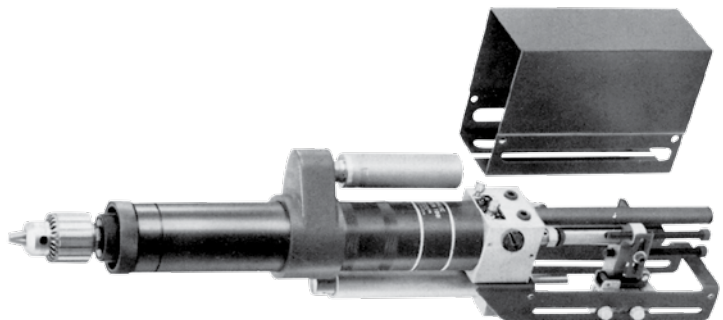

# Control Accessories



461-X



461-X with  
20975 Guard

## 41729 Dwell Control Kit

### APPLICATION INFORMATION

- Valves are 2-position, 3-way, manually actuated with spring return.
- Each valve can be plumbed to perform “normally open,” “normally closed,” “selector,” or any 2-way function.
- Use as operator controls to START tools or START cycle, or to EMERGENCY RETRACT tools, etc.
- Available in 1/8” NPT(F) ports and with 5/32” instant tube fittings.
- Equipped with 2 1/2” (63.5 mm) buttons in four colors.
- Design permits panel or side mounting.
- Optional full guard available.

To order, select the model number for port size and button color.  
Order P/N20975 Guard separately if required.

SPECIFICATIONS		
Valve Models w/ Instant Tube Fittings	Valve Models w/1/8” NPT(F) Ports	Button Color
461-1	460-1	Black
461-2	460-2	Red
461-3	460-3	Green
461-4	460-4	Yellow

OPERATING PRESSURE.....30 to 150 PSIG (2.1 to 10.4 bar)  
TEMPERATURE RANGE.....32° to 160°F (0° to 71°C)  
FLOW CAPACITY .....4.0 SCFM (1.9 dm3/s) with instant tube fittings;  
.....7.5 SCFM (3.6 dm3/s) with 1/8” NPT(F) ports.  
ACTUATING FORCE.....4 lbs. (17.8 N) at 100 PSIG (7 bar) inlet.

### APPLICATION EXAMPLE

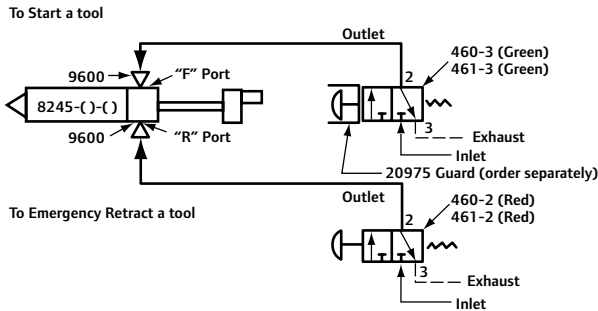

### PANEL MTG DRILLING LAYOUT

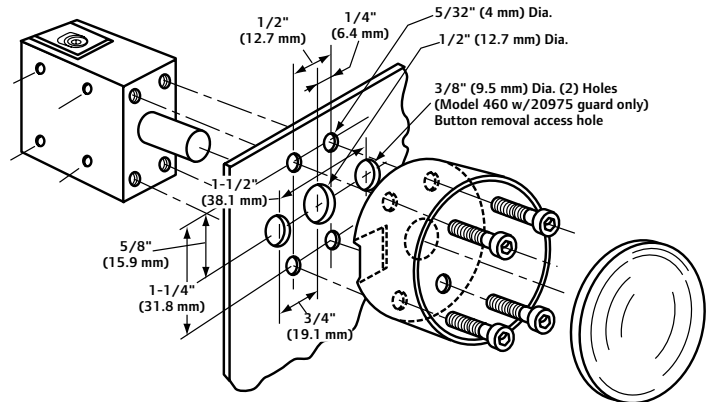

### DIMENSIONS & MOUNTING

#### MODEL 461-X

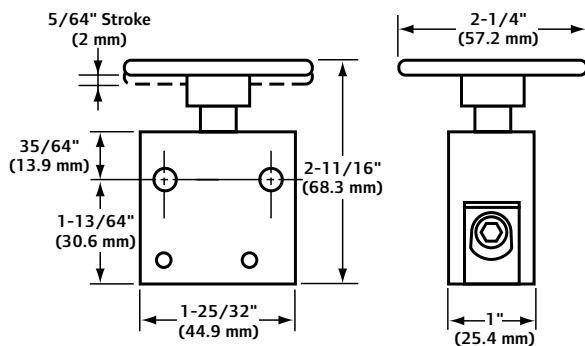

#### MODEL 461-X w/20975 Guard

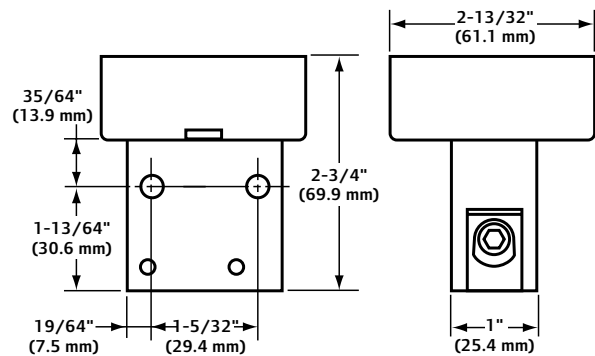

WARNING: Inappropriate or improper use, application, installation, service or maintenance of valves may create a hazardous or dangerous condition or situation. Please refer to the warning and cautions described in the pneumatic valves catalog or in the pneumatic logic controls catalog. Consult your distributor or representative for specific details.

The Circuit Accessories shown on pages 31 thru 38 are those elements most often used to control and interlock self-feed tools. A greater range of pneumatic valves and accessory components may be found in the pneumatic valves catalog and the pneumatic logic controls catalog.



# Control Accessories

## Model 206-2-c 3-way miniature valve

### APPLICATION INFORMATION

- A low cost two-position, pilot-actuated valve with spring return.
- Use for CYCLE COMPLETION for Lead Screw Tappers and tools with piston rod access (use "In N.O." for this).
- Can be plumbed to perform as "normally open," "normally closed," or as a diverter valve.
- Pilot actuator has a low friction U-cup seal on piston.
- Equipped with 5/32" instant tube fittings.
- Mounting holes are standard 1.0" electrical centers.

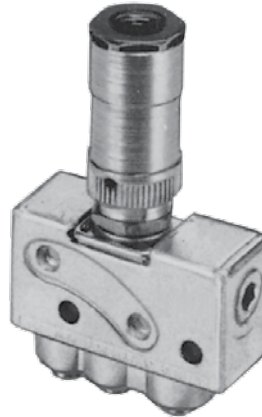

206-2-C

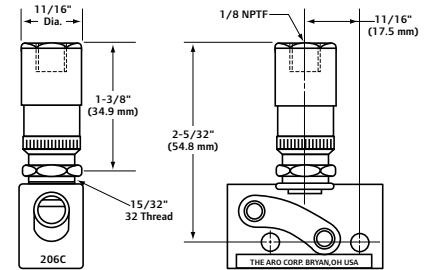

MINIMUM PILOT PRESSURE PSIG (bar)						
SUPPLY PRESSURE	25 (1.7)	50 (3.5)	75 (5.2)	100 (6.9)	125 (8.6)	150 (10.4)
Piped IN - N.N.P.	11.5 (0.8)	12.0 (0.8)	12.5 (.9)	13.0 (0.9)	13.5 (0.9)	14.0 (1.0)
Piped IN - N.P.	14.5 (1.0)	17.0 (1.2)	19.5 (1.3)	22.0 (1.5)	24.5 (1.7)	27.0 (1.9)

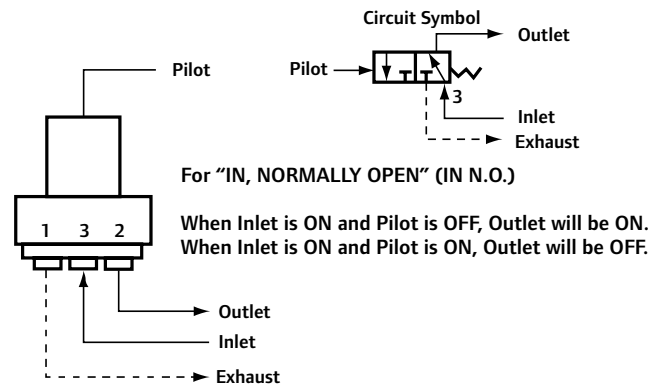
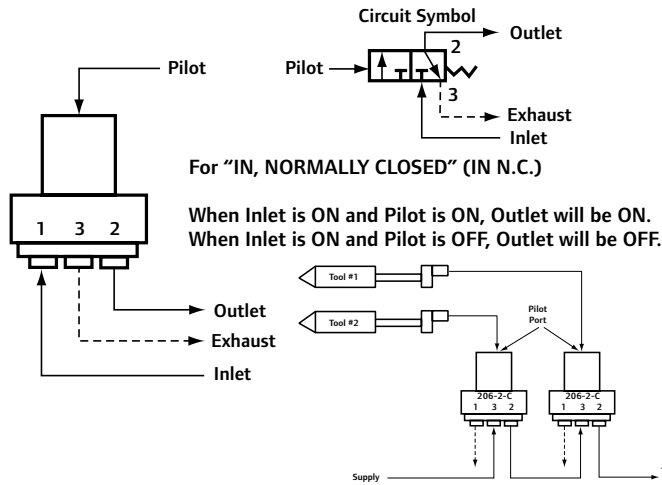
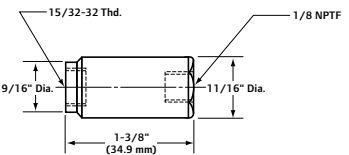

## Model PR10 single pulse relay valve

### APPLICATION INFORMATION

- Converts a continuous air signal into a single air pulse according to supply pressure used (see chart at right).
- Use to actuate a single device requiring momentary signals—from a limit valve supplying a continuous signal.
- Output turns ON when Input turns ON.
- Output turns OFF when preset time is reached (see chart at right).
- Removing Input resets valve for next cycle (see chart at right).
- Flow path indicated by arrow on valve body.
- Has a minimum pulse pressure of 35 PSIG (2.4 bar) and an operating range of 35 to 150 PSIG (2.4 to 10.4 bar).
- 1/8" NPT ports, inlet and outlet.



PR-10

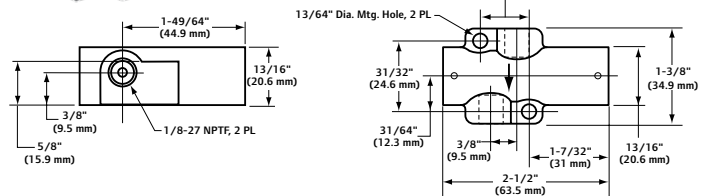

SUPPLY PSIG PRESSURE (bar)	PULSE DURATION ms	RESET TIME ms
50 (3.5)	125	160
75 (5.2)	110	170
100 (6.9)	105	180
125 (8.6)	100	190

NOTE: For best results, outlet of the PR10 should be close to inlet port of next device. Use care not to overtighten fittings in plastic body.

WARNING: Inappropriate or improper use, application, installation, service or maintenance of valves may create a hazardous or dangerous condition or situation. Please refer to the warning and cautions described in the pneumatic valves catalog or in the pneumatic logic controls catalog. Consult your distributor or representative for specific details.

# Control Accessories

## 200 Series miniature 3-way Limit Valves

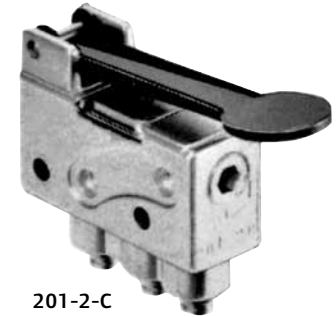

201-2-C

### APPLICATION INFORMATION

- Ideal for sensing position of moving machine devices, such as cylinders, slides, gates, etc.
- Valve can be plumbed to perform as “normally open,” “normally closed,” or any 2-way function.
- Fifteen actuator styles available—five manual and ten mechanical.
- Equipped with 5/32” instant tube fittings.
- Valves have zinc die cast body and stainless steel spool with Viton O-Ring Dynamic Seals / Buna-N Static Seals.

### DIMENSIONS

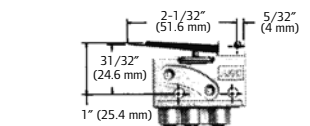
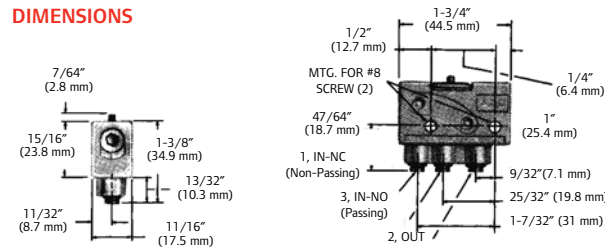

**MODEL 200-2-C PLAIN LEVER**  
Actuation: Force – 20 oz. (5.6 N) Stroke – .195” (5.0 mm)  
Overtravel – .055” (1.4 mm) Weight – 3.5 oz. (99 g)

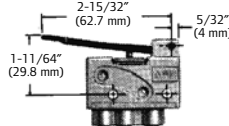

**MODEL 201-2-C FINGERTIP LEVER**  
Actuation: Force – 20 oz. (5.6 N) Stroke – .289” (7.3 mm)  
Overtravel – .086” (2.2 mm) Weight – 4 oz. (113 g)

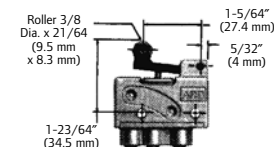

**MODEL 202-2-C SHORT ROLLER LEVER**  
Actuation: Force – 36 oz. (10.0 N) Stroke – .086” (2.2 mm)  
Overtravel – .024” (0.6 mm) Weight – 3.5 oz. (99 g)

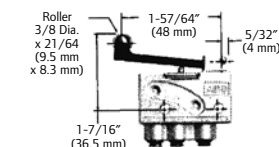

**MODEL 203-2-C LONGER ROLLER LEVER**  
Actuation: Force – 21 oz. (5.8 N) Stroke – .086” (2.2 mm)  
Overtravel – .024” (0.4 mm) Weight – 3.5 oz. (99 g)

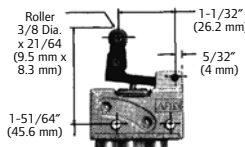

**MODEL 204-2-C ONE WAY, SHORT LEVER**  
Actuation: Force – 34 oz. (9.5 N) Stroke – .089” (2.3 mm)  
Overtravel – .027” (0.7 mm) Weight – 4 oz. (113 g)

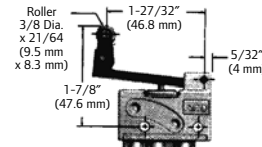

**MODEL 205-2-C ONE WAY, LONG LEVER**  
Actuation: Force – 23 oz. (6.4 N) Stroke – .164” (4.2 mm)  
Overtravel – .024” (0.6 mm) Weight – 4 oz. (113 g)

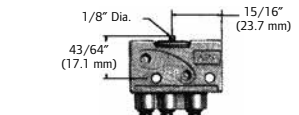

**MODEL 209-2-C PIN PLUNGER**  
Actuation: Force – 57 oz. (15.8 N) Stroke – .062” (1.6 mm)  
Overtravel – .015” (0.4 mm) Weight – 3 oz. (85 g)

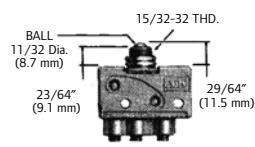

**MODEL 212-2-C BALL ROLLER, SHORT**  
Actuation: Force – 57 oz. (15.8 N) Stroke – .062” (1.6 mm)  
Overtravel – .015” (0.4 mm) Weight – 3.5 oz. (99 g)

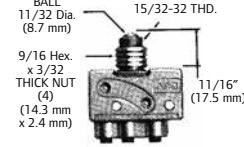

**MODEL 213-2-C BALL ROLLER, LONG**  
Actuation: Force – 57 oz. (15.8 N) Stroke – .062” (1.6 mm)  
Overtravel – .015” (0.4 mm) Weight – 3.5 oz. (99 g)

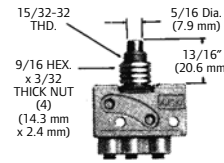

**MODEL 214-2-C STRAIGHT PLUNGER**  
Actuation: Force – 57 oz. (15.8 N) Stroke – .062” (1.6 mm)  
Overtravel – .089” (2.3 mm) Weight – 3.5 oz. (99 g)

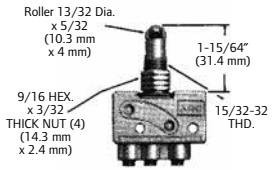

**MODEL 215-2-C ROLLER PLUNGER**  
Actuation: Force – 57 oz. (15.8 N) Stroke – .062” (1.6 mm)  
Overtravel – .089” (2.3 mm) Weight – 4 oz. (113 g)

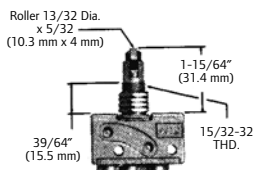

**MODEL 216-2-C CROSS-ROLLER PLUNGER**  
Actuation: Force – 57 oz. (15.8 N) Stroke – .062” (1.6 mm)  
Overtravel – .089” (2.3 mm) Weight – 4 oz. (113 g)

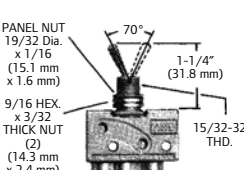

**MODEL 223-2-C RETAINED TOGGLE**  
Actuation: Force – 24 oz. (6.7 N) Stroke – 70°  
Weight – 3.5 oz. (99 g)

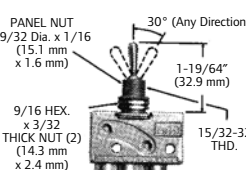

**MODEL 222-2-C CENTERING TOGGLE**  
Actuation: Force – 24 oz. (6.7 N) Stroke – 70°  
Weight – 3.5 oz. (99 g)

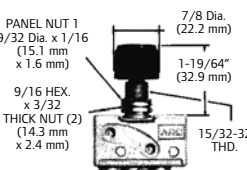

**MODEL 224-2-C PANEL BUTTON**  
Actuation: Force – 57 oz. (15.4 N) Stroke – .062” (1.6 mm)  
Overtravel – .015” (0.4 mm) Weight – 4 oz. (113 g)

To order, specify the desired model number shown below.

Stacking Kits contain all components (except valves) and instructions necessary for assembly. Valves must be ordered separately. Specify model number of kit according to the number of valves to be stacked	QUANTITY OF VALVES				
	2	3	4	5	6
Kit No.	225-2	225-3	225-4	225-5	225-6

### SPECIFICATIONS

**OPERATING PRESSURE** ..... 30 to 150 PSIG (2 to 10 bar)  
**TEMPERATURE RANGE** ..... 32° to 160° F (0° to 71° C)  
**FLOW CAPACITY** ..... 4.0 SCFM (1.9 dm<sup>3</sup>/s)  
**ACTUATING FORCE** ..... Forces listed below are for valve installed in “closed” mode. For forces in “open” mode, add 40%.

WARNING: Inappropriate or improper use, application, installation, service or maintenance of valves may create a hazardous or dangerous condition or situation. Please refer to the warning and cautions described in the pneumatic valves catalog or in the pneumatic logic controls catalog. Consult your distributor or representative for specific details.



# Control Accessories

## Model 59157 adjustable, single-pulse relay valve

### APPLICATION INFORMATION

- Converts a continuous air signal into a single air pulse of adjustable duration ranging from 0.8 to 7.5 seconds.
- Use to actuate feed tools or devices requiring momentary signals from a limit valve supplying a continuous signal.
- Output turns ON when Input turns ON.
- Output turns OFF when adjusted time is reached.
- Removing Input resets valve for next cycle.
- 1/8" NPT(F) ports.

### SPECIFICATIONS

OPERATING PRESSURE.....30 to 150 PSIG (2 to 10 bar)  
 TEMPERATURE RANGE.....32° to 160°F (0° to 71°C)  
 DIMENSIONS.....1 1/4" x 1 1/8" x 3 3/8" high (32 x 48 x 85 mm)  
 MOUNTING HOLES.....(2) 3/16" Dia. thru base in opposite corners of a 7/8" x 1 9/16" (22 x 40 mm) rectangular pattern.

59157

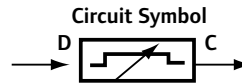
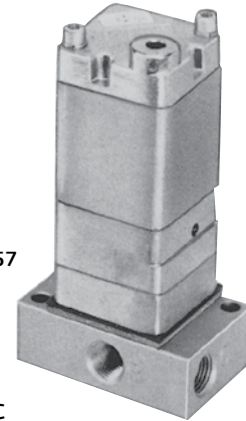

## "E" series 3-way & 4-way pilot valves

### APPLICATION INFORMATION

4-WAY VALVE—MODEL E212PD DOUBLE PILOT ACUATED, MODEL E212PS PILOT ACUATED SPRING RETURN

- Use to power double-acting cylinders up to 2.5" piston diameter.
- Use to power reversible air motors thru 0.5 HP. Motor always runs either forward or reverse rotation. Combine with 3-way valve for ON/OFF function, or choose a three position valve.
- Valves are two-position.
- 1/4" NPT(F) power air ports and 1/8" NPT(F) pilot ports for remote control.

3-WAY VALVE—MODEL E252PD DOUBLE PILOT ACUATED, MODEL E252PS PILOT ACUATED SPRING RETURN

- Use to power single-acting (spring return) cylinders up to 2.5" piston diameter.
- Use to power single-direction air motors thru 0.5 HP (ON/OFF function).

### SPECIFICATIONS

OPERATING PRESSURE......20 to 200 PSIG (1.4 to 13.8 bar)  
 Minimum pilot pressure—15 PSIG (1.0 bar)  
 TEMPERATURE RANGE.....-10° to 180°F (-23° to 82°C)  
 FLOW CAPACITY......26 SCFM (12 dm<sup>3</sup>/s)

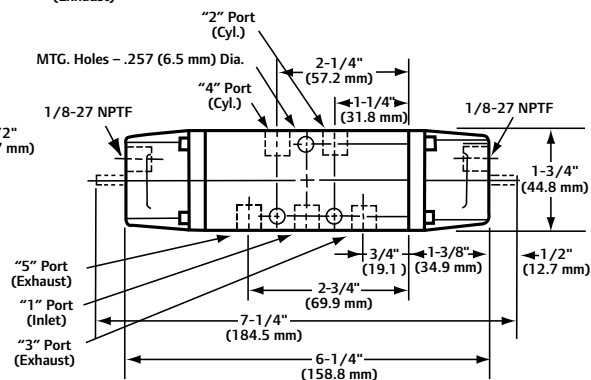
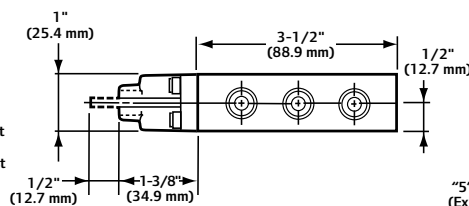
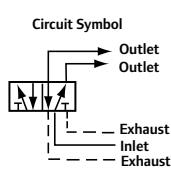
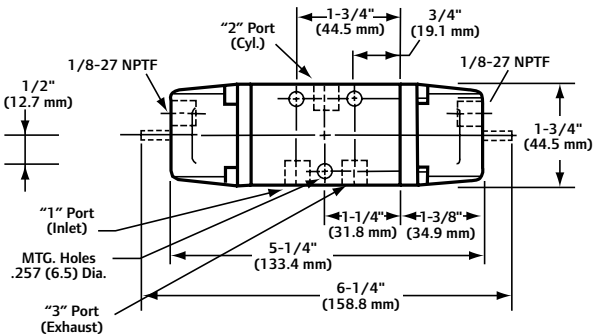
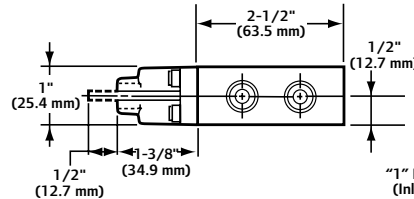
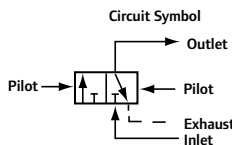

WARNING: Inappropriate or improper use, application, installation, service or maintenance of valves may create a hazardous or dangerous condition or situation. Please refer to the warning and cautions described in the pneumatic valves catalog or in the pneumatic logic controls catalog. Consult your distributor or representative for specific details.

# Control Accessories

## Two-Hand Anti-Tie-Down Control Packages

### APPLICATION INFORMATION

- Ideal for machines where position of operator's hands must be monitored.
- Actuate and hold both air valve buttons concurrently to maintain an output air signal.
- If either push button is released, the output air signal is exhausted, indicating the operator's hands are no longer in position.
- Operating Pressures: 50-125 PSI (3.5-8.6 bar). Designed to comply with OSHA regulations.

**Warning:** These provide only the anti-tie down logic function and are not stroke limiting devices. On machines with full revolution clutches and/or where repeat cycles can occur, approved safety and/or single stroke devices must be used in conjunction with the anti-tie down units.

### ELEMENTS

#### 59191 Base Mounted

- Element has three 1/8" NPTF ports on top. 2 inputs, 1 output.
- Element is base mounted. Ordering Information: Order push button valves separately.

### PACKAGES

#### 59808

- Includes two enclosures with green push button valves separated by a length of flexible conduit. External supply and output to machine is made by 5/32" (4mm) instant tube fittings.
- Comes assembled with all internal connections ready to install on machine.
- Palm Buttons are 30" center to center.

#### 59809

- Green push buttons located on opposite ends of a single enclosure.
- External supply and output to machine is made by 5/32" (4mm) instant tube fittings.
- Comes assembled with all internal connections ready to install on machine.

#### 59003-842

- Unassembled package.
- Includes 59191 anti-tie-down block, two 461-3 palm buttons with 20975 guards, 10 feet of 5/32" tubing and fittings for 59191.
- Customer can custom fit components to machine.



59191

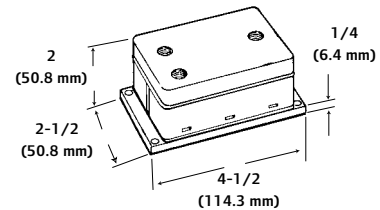

59808

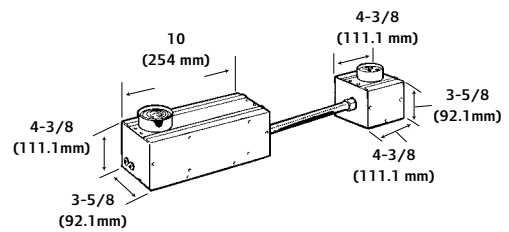

59809

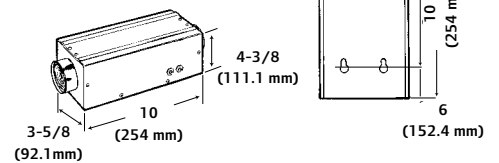

### 59003-842 CONTROL ASM.

59756-4 (3) Elbow Fittings for 5/32" Tubing

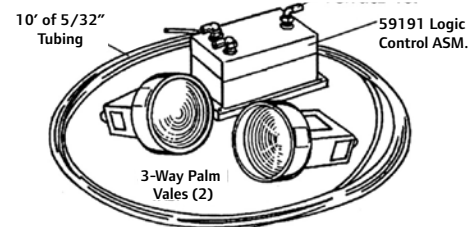

# Control Accessories

## Model 37750 Terminal Manifold

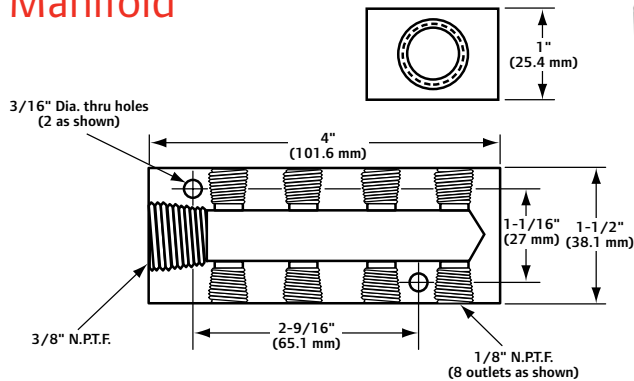

**Application example**  
To start several self-feed tools  
with one signal—

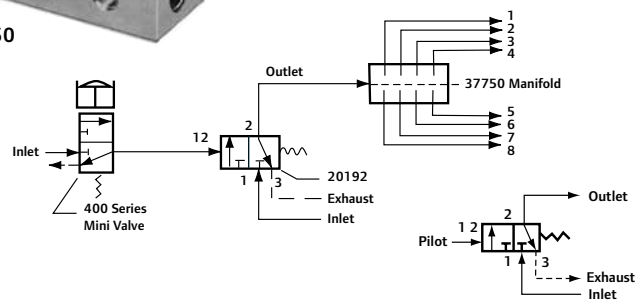

### APPLICATION INFORMATION

- Eight station distribution manifold for control circuit signals.
  - One 3/8" NPT(F) supply port and eight 1/8" NPT(F) signal ports.
- NOTE: Mounting screws not included.

## Tubing, Fittings & Connectors

Y-Connector	Tube Size	
59482	5/32	
Male Connector	Tube Size	NPT
59474-4	5/32	1/8
59474-56	1/4	1/8
59474-156	1/4	1/4
59474-256	1/4	3/8
Tubing (100')	Tube Size	
59690-4	5/32	
Male Elbow	Tube Size	NPT
59756-103	5/32	#10-32
59756-4	5/32	1/8
59756-56	1/4	1/8
59756-156	1/4	1/4
Male Branch Tee	Tube Size	NPT
59757-4	5/32	1/8
59757-56	1/4	1/8
59757-156	1/4	1/4
Plug	Tube Size	
59763-4	5/32	
59763-56	1/4	



Union	Tube Size	
59759-4	5/32	
59759-56	1/4	
Union Elbow	Tube Size	
59760-4	5/32	
59760-56	1/4	
Union Tee	Tube Size	
59761-4	5/32	
59761-56	1/4	
Union Bulkhead	Tube Size	
59762-4	5/32	
59762-56	1/4	
Expander Tube Male	Tube Size	NPT
59765-4	5/32	1/4
Reducer Tube Male	Tube Size	NPT
59765-56	1/4	5/32



Maximum Working Pressure Vacuum to 250 PSI (17 bar)  
Temperature Range - +5°F to 160°F (-15°F to 71°C)  
Tubing Material: Nylon II

# Control Accessories

## Inline "And" & "Or" Circuit Components

### APPLICATION INFORMATION

- Miniature, low cost elements to provide "AND" and "OR" functions in pneumatic control circuitry.
- Require #10-32 male connector for each of three ports.

## Model 59914 "Or"

Model 59914 "OR" function (shuttle) connects two air signals to a common output. Either input, when applied, flows directly to the output port. An internal poppet prevents a loss of pressure from the input not in use. The 59914 "OR" function can replace many small metal shuttles and logic elements presently in use. It is lightweight, corrosion-resistant and easy to install.

It can be used to allow additional input of a signal into a circuit.

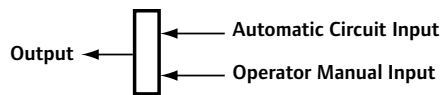
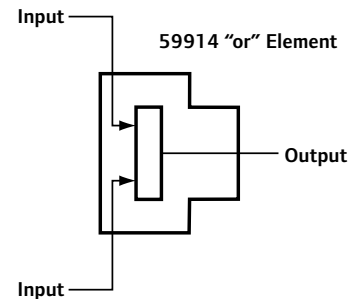
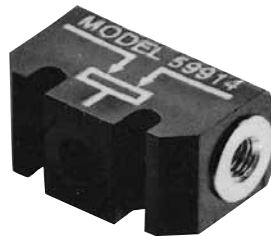

## Model 59913 "And"

Model 59913 "AND" function also connects two air signals to a common output. Both input signals must be ON to create an output signal. A loss of pressure at either input will cause the output to go OFF. The 59913 "AND" function is used to interlock two signals for sequence or safety. It can replace larger pilot-operated valves and logic elements previously used for this purpose. It is lightweight, corrosion-resistant and easy to install.

It can be used to sum signals to achieve an action after all signals are present.

EXAMPLE: Unclamp a part when all tools are retracted.

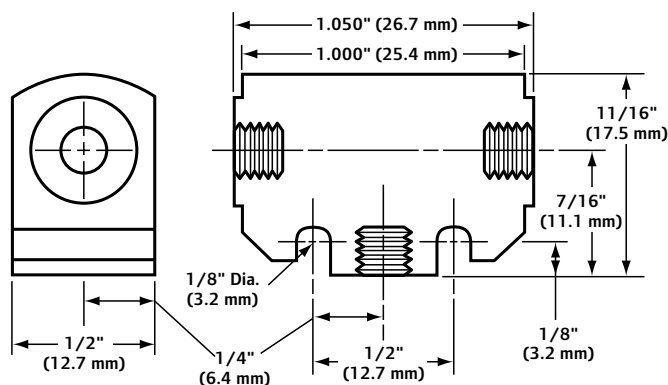
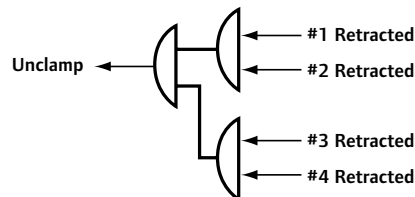
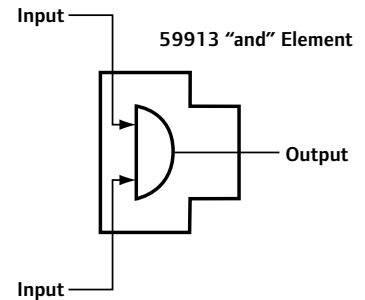
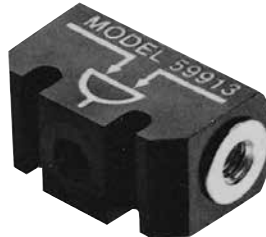

### SPECIFICATIONS

OPERATING PRESSURE	.....	.30 to 150 PSIG (2 to 10 bar)
TEMPERATURE RANGE	.....	.32° to 160°F (0° to 71°C)
..FLOW CAPACITY *	.....	"OR" = 4.0 SCFM (1.9 dm <sup>3</sup> /s)
	.....	"AND" = 3.2 SCFM (1.5 dm <sup>3</sup> /s)
PORTS	.....	#10-32 Female Thread
BODY MATERIAL	.....	Acetal Resin
INSERTS	.....	Aluminum
SHUTTLE/POPPET	.....	Buna-N
	.....	*90 PSIG (6.2 bar) supply, 75 PSIG (5.2 bar) outlet.

WARNING: Inappropriate or improper use, application, installation, service or maintenance of valves may create a hazardous or dangerous condition or situation. Please refer to the warning and cautions described in the pneumatic valves catalog or in the pneumatic logic controls catalog. Consult your distributor or representative for specific details.

# Mounting Accessories

To complement its comprehensive line of automatic production tools, offers a variety of mounting options to meet countless fixture requirements. The availability of a wide assortment of standard mounting components provides the user with three important benefits:

**PRECISION.** All clamping devices are designed specifically for automatic production tools to provide rigid mounting.

**VERSATILITY.** Mounting components permit automatic production tools to be positioned vertically, horizontally, or at 3-dimensional angles in relation to the workpiece. They are also suitable for clamping other machine elements.

**LOW COST.** Standard components for mounting tools minimize the need to construct special holding or clamping devices. This results in low jiggling costs, easier service and higher reuse value.

To select and order the proper mounting components, please consider the

following—

1. Identify the particular series of tool to be used, i.e., Bant-A-Matic, Par-A-Matic, etc.
2. From all the possible mounting options for automatic production tools illustrated below, note those available for the series tool to be used.
3. Keeping in mind the attitude of the tool to the workpiece and the amount of space in which the mount must fit, select the best available mounting accessory for the application from pages 39-46 (dimensions are shown for each mount).

**NOTE:** When selecting either stationary or portable nose mounting, pay particular attention to thread sizes and drill ranges.

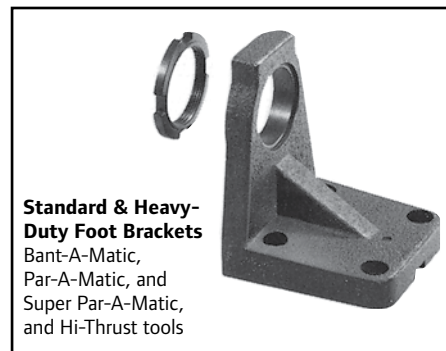
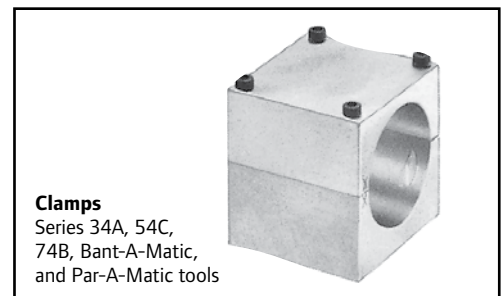
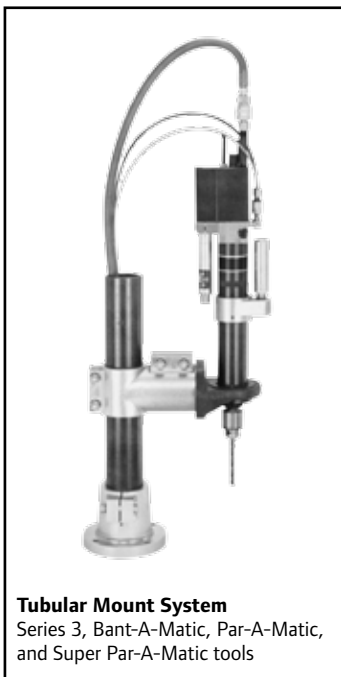
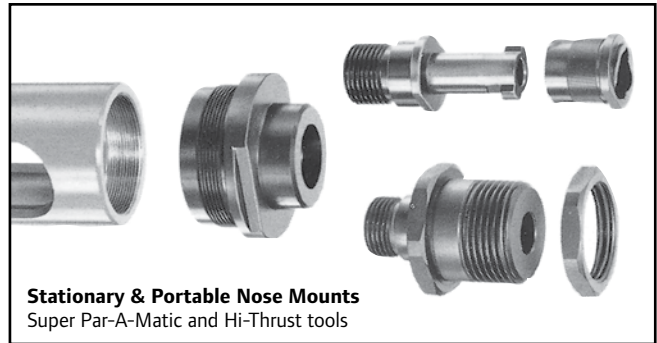
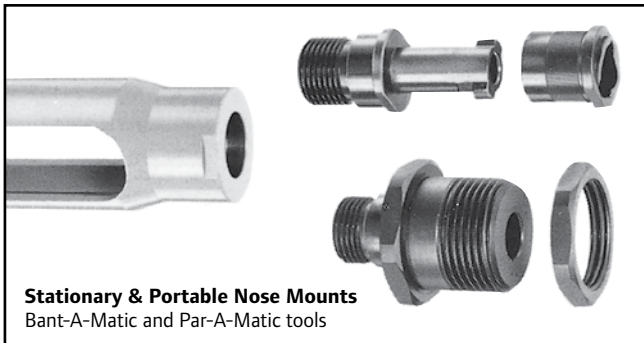

# Mounting Accessories

## Bant-A-Matic Series



**Flange Bracket**  
P/N 39486  
(Includes Nut)

39476 Nut 1-7/16-18 L.H. Thread

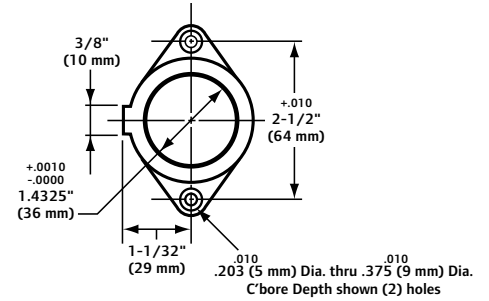
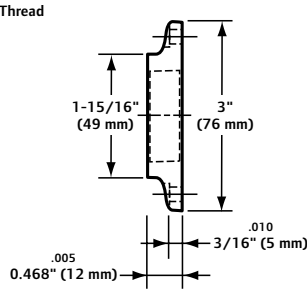
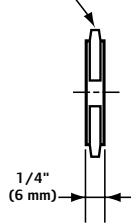

**Standard-duty Foot Bracket**  
P/N 39485-1  
(Includes Nut)

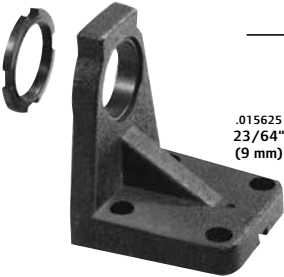
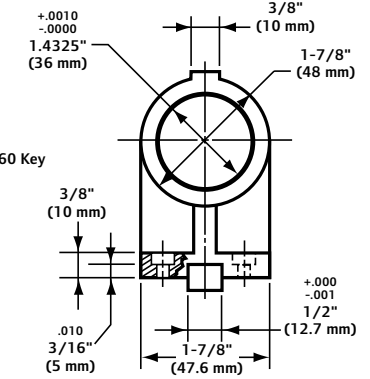
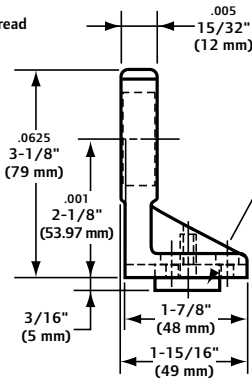
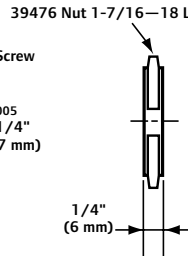
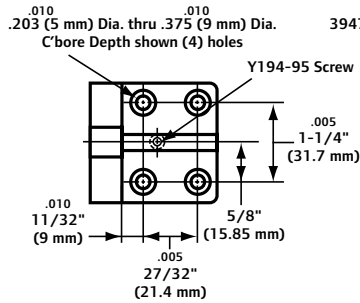

**Heavy-duty Foot Bracket**  
P/N 45053  
(Includes Nut)

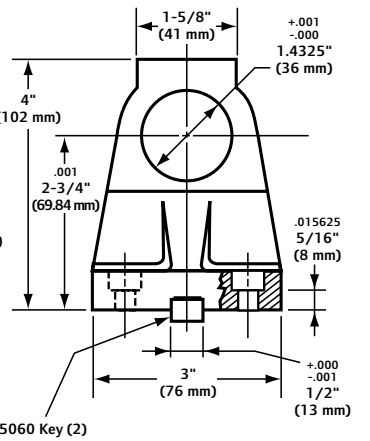
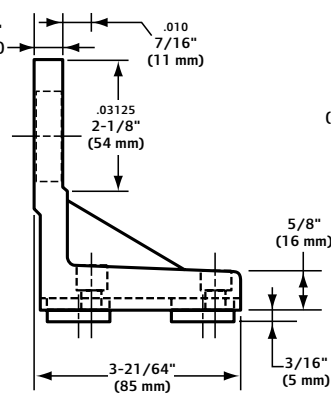
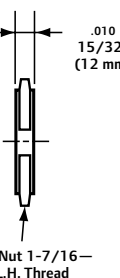
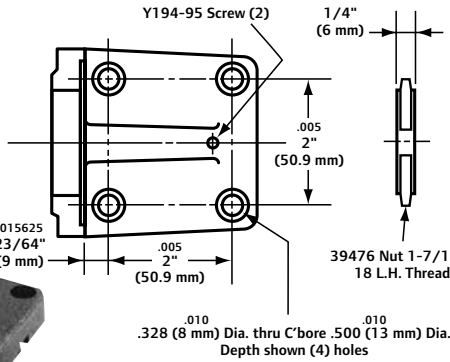

**Block Clamp**  
P/N 36042

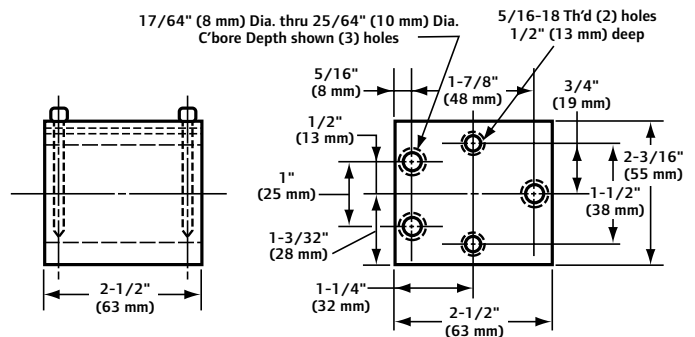
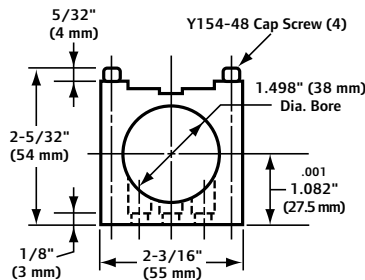

# Mounting Accessories

## Par-A-Matic Series



**Flange Bracket**  
P/N 38877  
(Includes Nut & Ring)

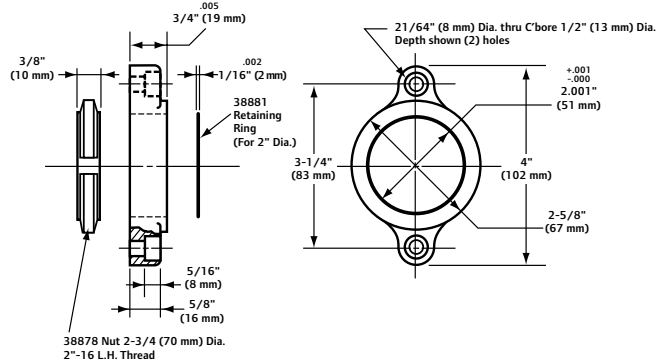

**Standard-duty Foot Bracket**  
P/N 38875-1  
(Includes Nut & Ring)

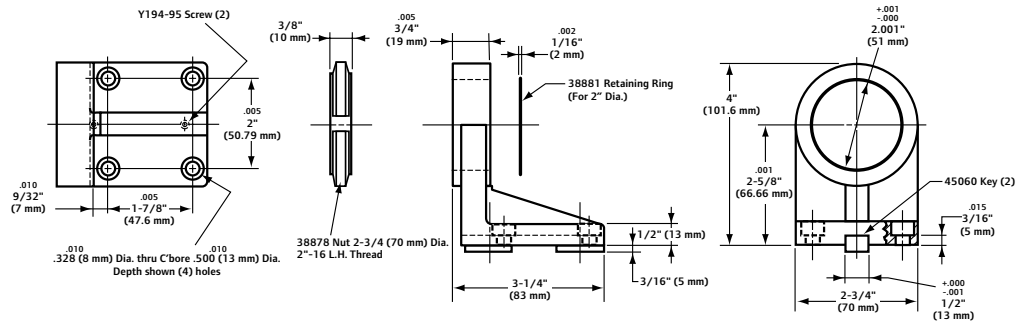

**Heavy-duty Foot Bracket**  
P/N 45055  
(Includes Nut & Ring)

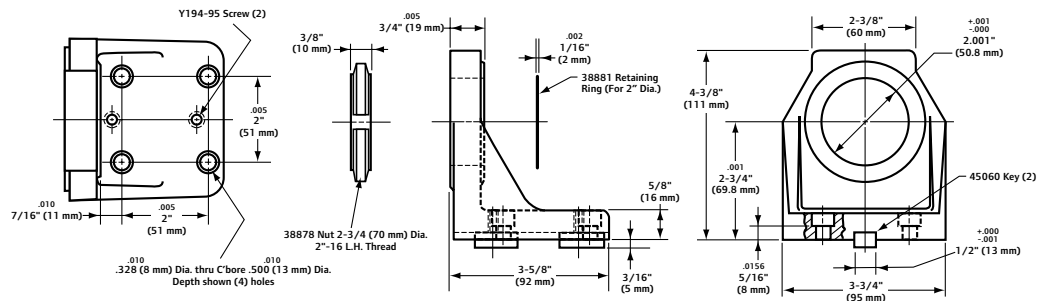

**Block Clamp**  
P/N 35283

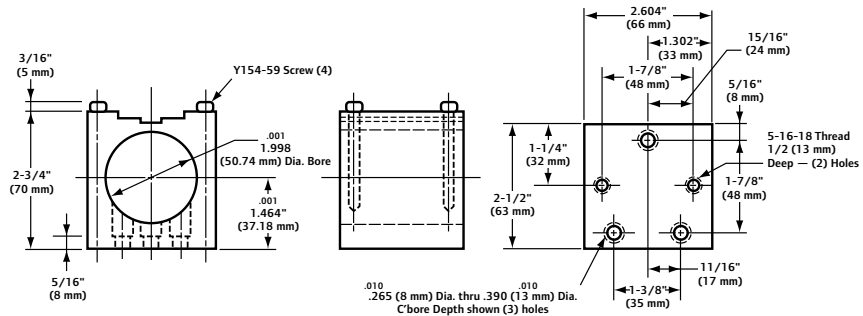

# Mounting Accessories

## Super Par-A-Matic Series



**Flange Bracket**  
P/N 40589  
(Includes Nut & Ring)

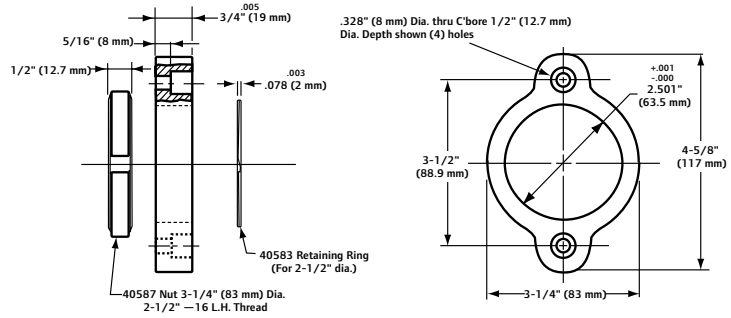

**Standard-duty**  
**Foot Bracket**  
P/N 40588-1  
(Includes Nut & Ring)

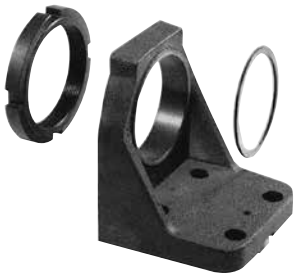
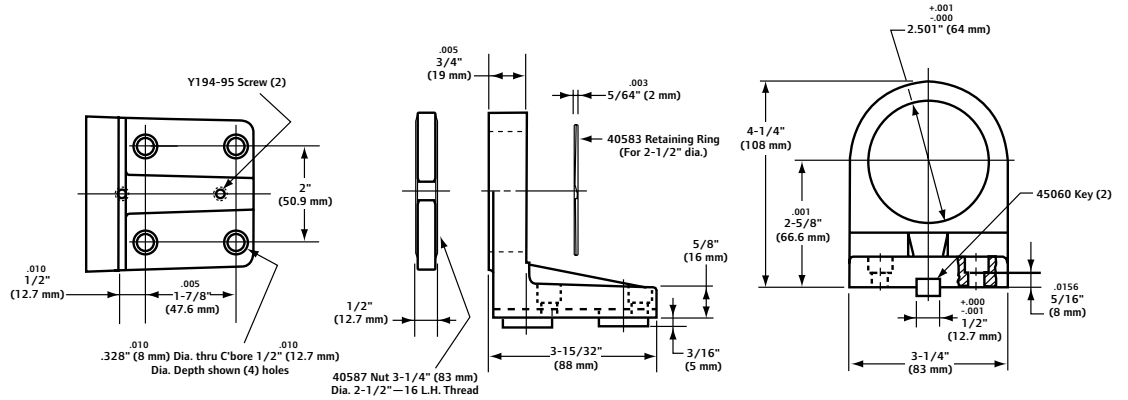

**Heavy-duty**  
**Foot Bracket**  
P/N 45056  
(Includes Nut & Ring)

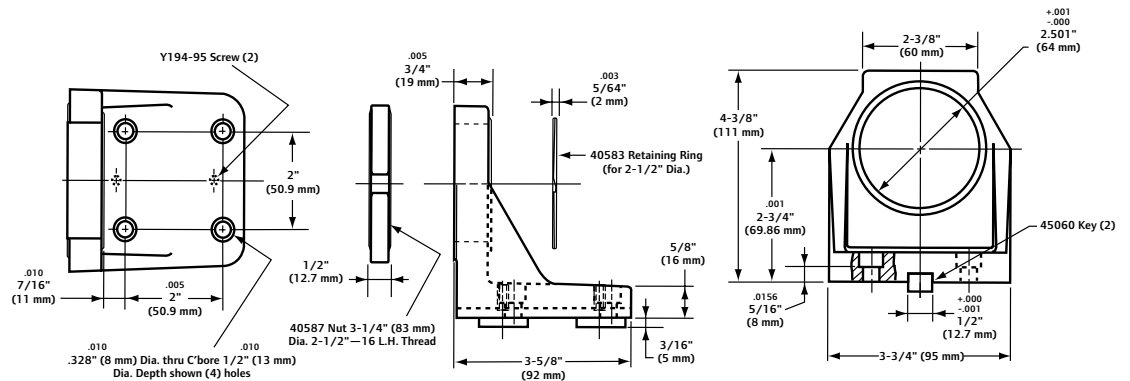





# Mounting Accessories

## Tubular Mounting System

The tubular mounting system is an extremely versatile method of mounting Bant-A-Matic, Par-A-Matic, and Super Par-A-Matic Series tools. Available mounting components accommodate endless fixture requirements and permit the positioning of tools at virtually any angle to the workpiece.

The following illustrations show just a few examples of the many fixture possibilities.

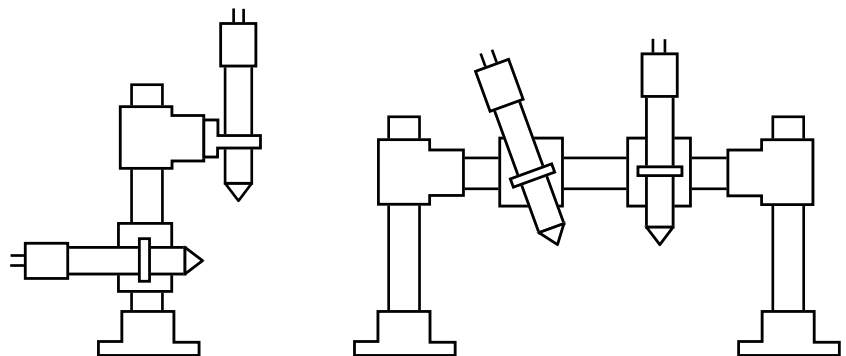
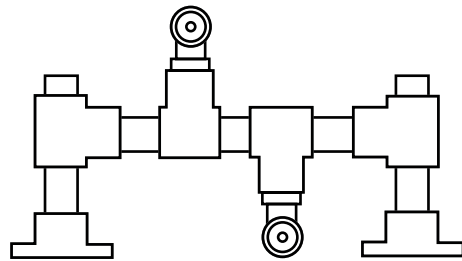
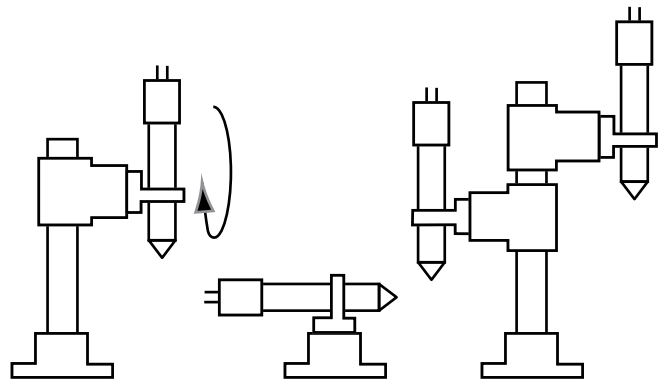

# Mounting Accessories

## 43788 Base Mount Assembly

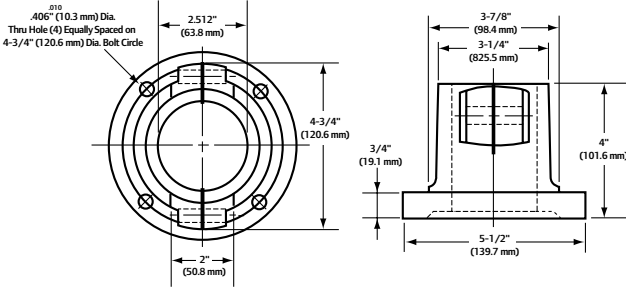

## 43791-( ) Mounting Tube

Mounting Tube*	Length "L"
43791-6	6.0" (152 mm)
43791-12	12.0" (305 mm)
43791-18	18.0" (457 mm)
43791-24	24.0" (610 mm)
43791-30	30.0" (762 mm)

\*Longer tubes available upon request.

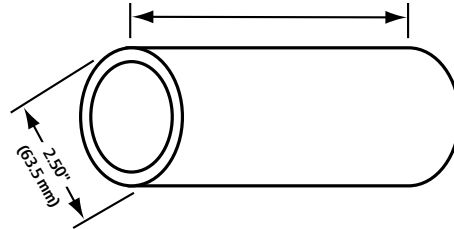

## 43790 Tee Mount

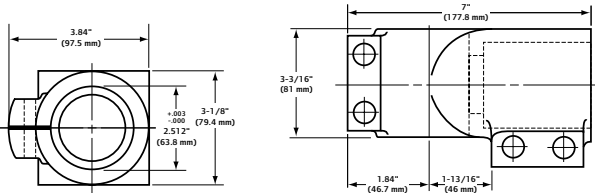
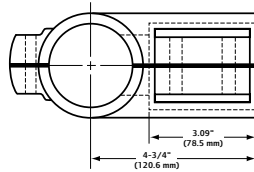

Designed to connect a Tool Mount Assembly to a Mounting Tube. Forms a right angle from the mounting tube.

## 43786-( ) Tool Mount Assembly

Designed to hold Bant-A-Matic, Par-A-Matic and Super Par-A-Matic Series tools. Tool Mount Assemblies come complete with a mounting bracket, lock nut and retaining ring.



Tool Series	Tool Mount Assembly	Mounting Bracket	Lock Nut	Retaining Ring	Diameter "D"
Bant-A-Matic	43786-1	43785-1	39476	None	1.432" (36.4 mm)
Par-A-Matic	43786-2	43785-2	38878	38881	2.001" (50.8 mm)
Super Par-A-Matic	43786-3	43785-3	40587	40583	2.501" (63.5 mm)

## 04333860 Tool Mount

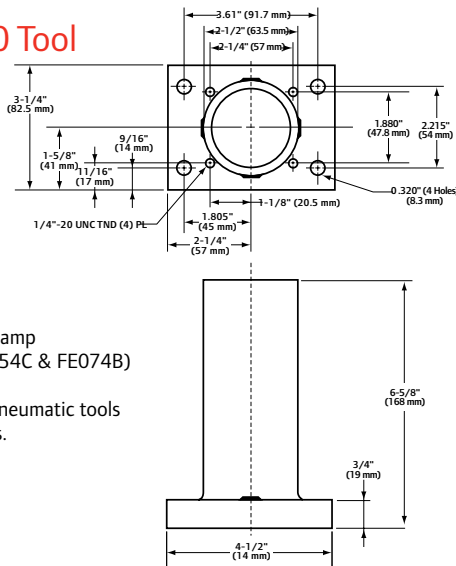

Accepts 49690 Clamp (for FE034A, FE054C & FE074B)

Adapts electric/pneumatic tools to tubular mounts.

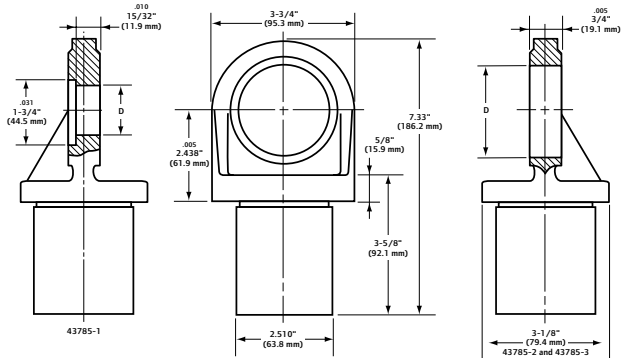

# Mounting Accessories

## Nose Mounting With A Portable Lock Bushing Bant-A-Matic And Par-A-Matic Drills

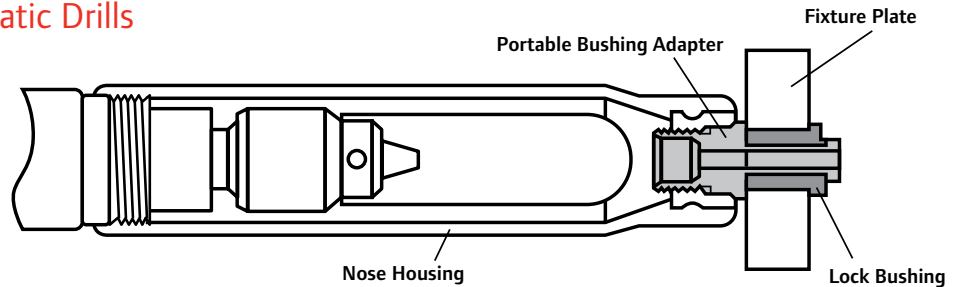

## Nose Mounting With A Portable Lock Bushing Super Par-A-Matic And Hi-Thrust Drills

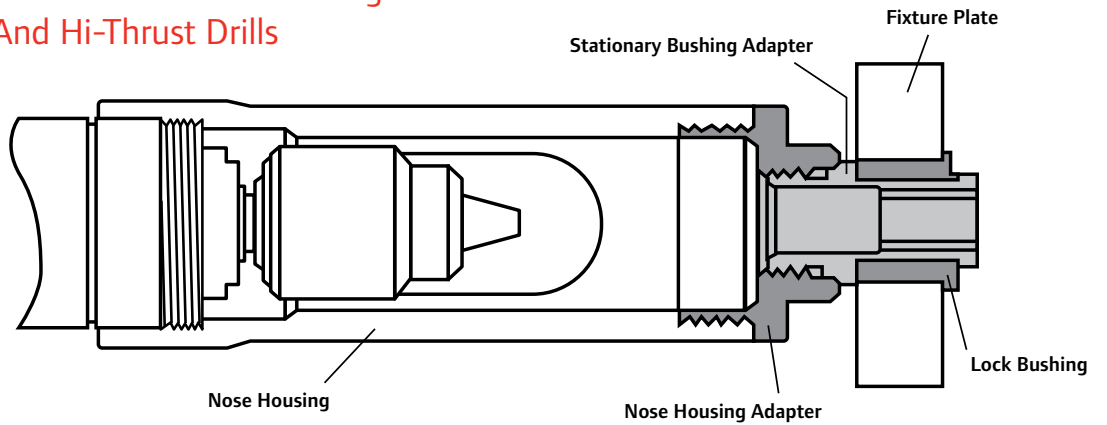

## Nose Mounting With A Stationary Lock Bushing Bant-A-Matic And Par-A-Matic Drills

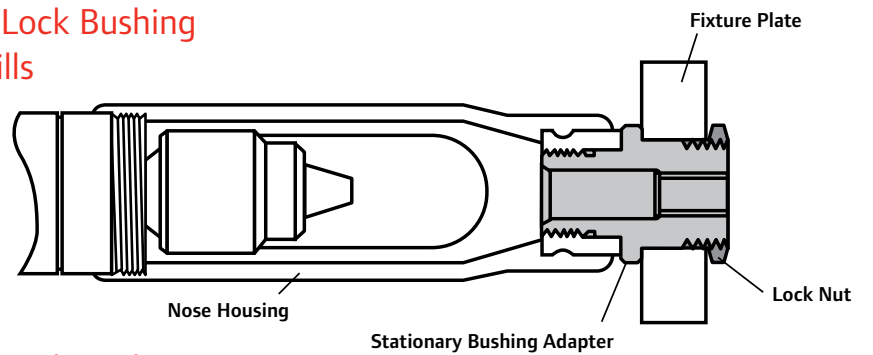

## Nose Mounting With A Stationary Lock Bushing Super Par-A-Matic And Hi-Thrust Drills

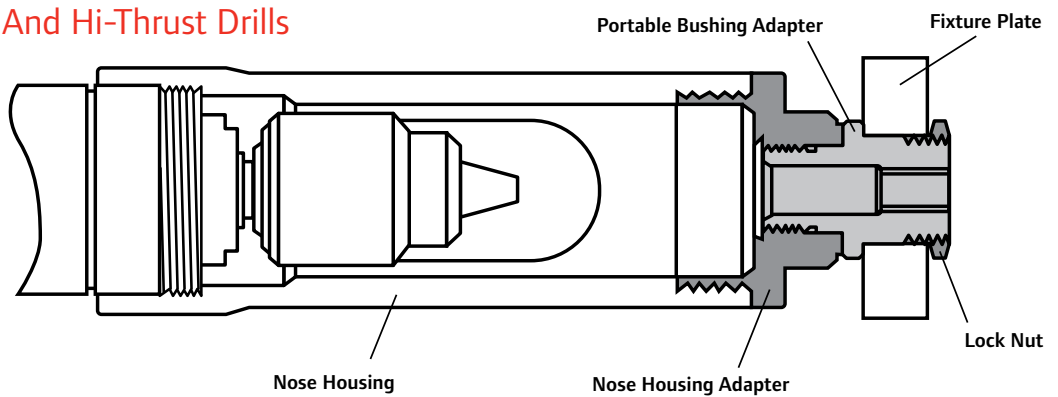

# Mounting Accessories

## Nose Housing

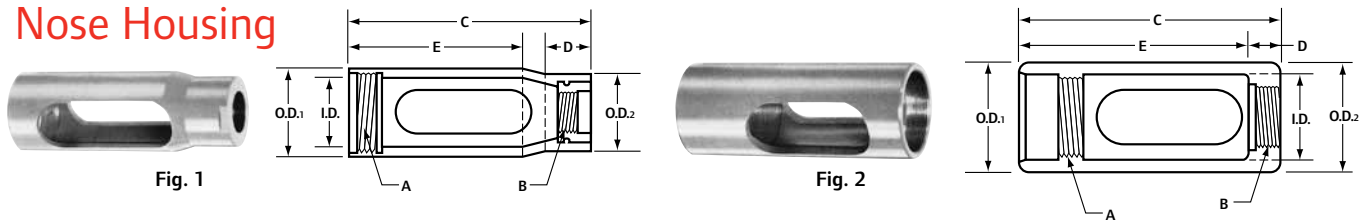

Drill Model	Nose Housing	THREAD SIZES		LENGTH C in (mm)	DIAMETER					
		A To Tool	B To Bushing/ Adapter		O.D. 1 in (mm)	O.D. 2 in (mm)	I.D. in (mm)	D. in (mm)	E. in (mm)	
<b>BANT-A-MATIC DRILLS (FIGURE 1)</b>										
8245/8345-202-1 & 2	35918	1-7/16"-18	3/4"-16	5.7	1.6	1.4	1.3	1.0	4.2	
8245/8345-B45-1 & 2		UNEF-2B L.H.	UNF-2B L.H.	(145)	(41)	(36)	(33)	(25)	(107)	
8245/8345-B30-1 & 2										
8245/8345-B8-1 & 2										
8245/8345-101-1 & 2										
8245/8345-202-3										
8245/8345-101-3	35917	1-7/16"-18	3/4"-16	6.4	1.6	1.4	1.3	1.1	4.8	
8245/8345-B45-3		UNEF-2B L.H.	UNF-2B L.H.	(163)	(41)	(36)	(33)	(28)	(122)	
8245/8345-B30-3										
8245/8345-B8-3	40804	1-7/16"-18	3/4"-16	7.5	1.6	1.4	1.3	1.1	6.0	
		UNEF-2B L.H.	UNF-2B L.H.	(191)	(41)	(36)	(33)	(28)	(152)	
<b>PAR-A-MATIC DRILLS* (FIGURE 1)</b>										
8255/8355-171-1 & 2	35722	2"-16 UN-2B L.H.	3/4"-16 UNF-2B L.H.							
8255/8355-A50-1 & 2	or			4.75	2.2	1.9	1.75	1.1	3.0	
8255/8355-A28-1 & 2	35720	2"-16 UN-2B L.H.	1"-14 UNF-2B L.H.	(121)	(56)	(48)	(44)	(28)	(76)	
8255/8355-A21-1 & 2	or									
	36495	2"-16 UN-2B L.H.	1-1/4"-12 UNF-2B L.H.							
8255/8355-A14-1 & 2										
8255/8355-101-1 & 2										
8255/8355-A8-1 & 2	38852	2"-16 UN-2B L.H.	3/4"-16 UNF-2B L.H.							
8255/8355-A5-1 & 2	or									
8255/8355-171-3	38853	2"-16 UN-2B L.H.	1"-14 UNF-2B L.H.	6.1	2.2	1.9	1.75	1.1	4.4	
8255/8355-101-3	or			(155)	(56)	(48)	(44)	(28)	(112)	
8255/8355-A50-3	38854	2"-16 UN-2B L.H.	1-1/4"-12 UNF-2B L.H.							
8255/8355-A28-3										
8255/8355-A21-3										
	40810	2"-16 UN-2B L.H.	3/4"-16 UNF-2B L.H.							
		40810	2"-16 UN-2B L.H.	3/4"-16 UNF-2B L.H.						
8255/8355-A14-3	or			7.25	2.2	1.9	1.75	1.1	5.5	
8255/8355-A8-3	40811	2"-16 UN-2B L.H.	1"-14 UNF-2B L.H.	(184)	(56)	(48)	(44)	(28)	(140)	
8255/8355-A5-3	or									
		40812	2"-16 UN-2B L.H.	1-1/4"-12 UNF-2B L.H.						
<b>SUPER PAR-A-MATIC DRILLS* (FIGURE 2)</b>										
8265-170-1 & 3										
8265-46-1 & 3	40584-1	2-1/2"-16	2-3/8"-16	6.0	2.9	2.7	2.0	0.88	3.9	
8265-25-1 & 3		UN-2B L.H.	UN-2B L.H.	(152)	(74)	(69)	(51)	(22)	(99)	
8265-12-1 & 3										
8265101-1 & 3	40584-2	2-1/2"-16	2-3/8"-16	7.8	2.9	2.7	2.0	0.88	5.7	
8265-6-1 & 3		UN-2B L.H.	UN-2B L.H.	(198)	(74)	(69)	(51)	(22)	(145)	
8265-3-1 & 3										
<b>HIGH-THRUST DRILLS (FIGURE 2)</b>										
8670(-)-3	45188	2-7/8"-16	2-3/8"-16	9.8	3.6	3.6	2.9	1.0	6.1	
		UN-2B L.H.	UN-2B L.H.	(249)	(92)	(92)	(74)	(25)	(155)	

\*Nose housing used will depend upon the size of the Portable or Stationary Bushing Adapter needed.

NOTE: Nose housing with bushing adapter may be used as a drill guide in conjunction with either a Collet-type Foot Bracket or a Block Clamp. Use appropriate press-fit drill guide bushing in a Stationary Bushing Adapter or Portable Bushing Adapter.

Nose Housings of significant weight: 44971-1 = 1.0 lbs.(.45 kg), 44971-2 = 1.5 lbs.(.68 kg), 45188 = 7.5 lbs.(3.4 kg).

# Mounting Accessories

## Nose Housing Adapters\*

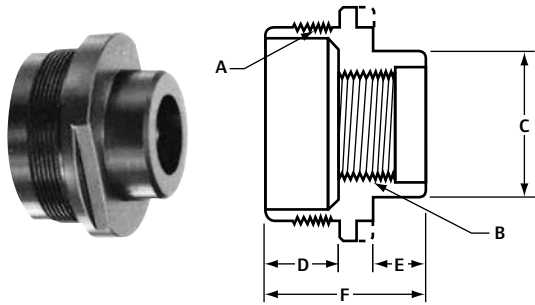

Nose Housing Adapter	THREAD SIZES					
	A To Nose Housing	B To Stationary/ Portable Bushing	C in (mm)	D in (mm)	E in (mm)	F in (mm)
33812		3/4"-16 UNF-2B L.H.	1.75 (44)			
33751		1"-14 UNF-2B L.H.	1.75 (44)	1.0	0.625	1.875
33764	2-3/8"-16 UN-2A L.H.	1-1/4"-12 UNF-2B L.H.	1.75 (44)	(25.4)	(16)	(47)
34075		1-1/2"-12 UNF-2B L.H.	2.0 (51)			
46695		2"-16 UN-2B L.H.	2.75 (69)			

\*Use with nose mounting for Super Par-A-Matic and Hi-Thrust Drills.

## Stationary Lock Bushings

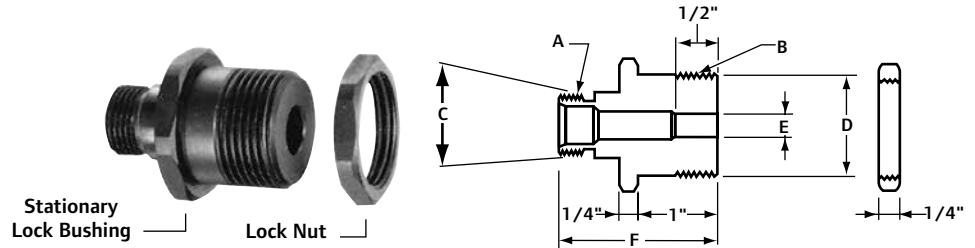

Drill Dia Range in	Stationary Lock Bushing Adapter, Part No.	Lock Nut Part No.	A Thread Size (To Nose Housing)	B Mounting Thread	C Pilot Dia. in (+.0000, -.0005)	D Pilot Dia. in (+.000, -.002)	E - Press Fit Dia., For Headless Press Fit Drill Bushing in (+.0005, -.0000)	F Length of Stationary Lock Bushing Adapter in
.0135 - .0995	36646	38850 (1-1/2 HEX)	3/4"-16 UNF-2A, L.H.	1-1/4"-12 UNF-2A	.8115	1.248	.2036	2.000
.0980 - .1406	36647	38850 (1-1/2 HEX)	3/4"-16 UNF-2A, L.H.	1-1/4"-12 UNF-2A	.8115	1.248	.2506	2.000
.1250 - .1935	36648	38850 (1-1/2 HEX)	3/4"-16 UNF-2A, L.H.	1-1/4"-12 UNF-2A	.8115	1.248	.3131	2.000
.1875 - .3160	36649	38850 (1-1/2 HEX)	3/4"-16 UNF-2A, L.H.	1-1/4"-12 UNF-2A	.8115	1.248	.5007	2.000
.1875 - .3160	36650	38850 (1-1/2 HEX)	1"-14 UNF-2A, L.H.	1-1/4"-12 UNF-2A	1.0615	1.248	.5007	2.187
.3125 - .5312	36651	38850 (1-1/2 HEX)	1-1/4"-12 UNF-2A, L.H.	1-1/4"-12 UNF-2A	1.3115	1.248	.7508	2.187
.5000 - .7656	46088	46089 (1-5/8 HEX)	1-1/2"-12 UNF-2A, L.H.	1-1/2"-12 UNF-2A	1.5710	1.498	1.0008	2.187

Note: Stationary Lock Bushing and Lock Nut must be ordered separately.

## Portable Lock Bushings

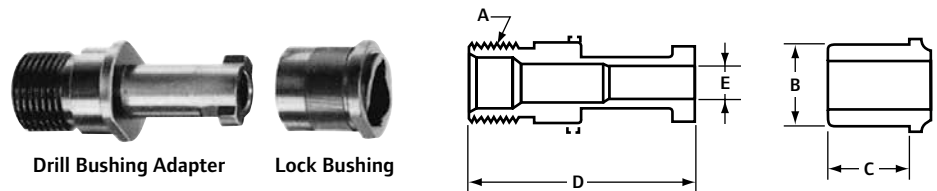

Drill Dia Range in	Portable Drill Bushing Adapter, Part No.	Lock Bushing Part No.	A Thread Size (To Nose Housing)	B Lock Bushing Press Fit Dia. in (+.000, -.001)	C Length of Press Fit Dia. B in	D Length of Portable Drill Bushing in	E - Press Fit Dia., For Headless Press Fit Drill Bushing in (+.0005, -.0000)
.0135-.0995	35214	35215	3/4"-16 UNF-2A, L.H.	0.686	0.750	2.172	0.2036
.0980-.1406	35216	35217	3/4"-16 UNF-2A, L.H.	0.749	0.750	2.172	0.2506
.1250-.1935	35218-1	35219	3/4"-16 UNF-2A, L.H.	0.811	0.750	2.172	0.3131
.1875-.3160	35220	35221-1	1"-14 UNF-2A, L.H.	0.999	0.750	2.203	0.5007
.3125-.5312	35222-1	35223	1-1/4"-12 UNF-2A, L.H.	1.374	1.000	2.516	0.7508
.5000-.7656	35224	35225	1-1/2"-12 UNF-2A, L.H.	1.749	1.125	2.656	1.0008

Note: Stationary Drill Bushing and Lock Bushing must be ordered separately.

# Dimensional Data

## Bant-A-Matic Drills 8245-B( )-1 And 8345-B( )-1

Tool Weight 4.2 lbs.

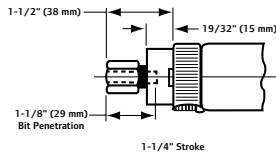

Shows built-in-collet used on 19,000 RPM Tools.

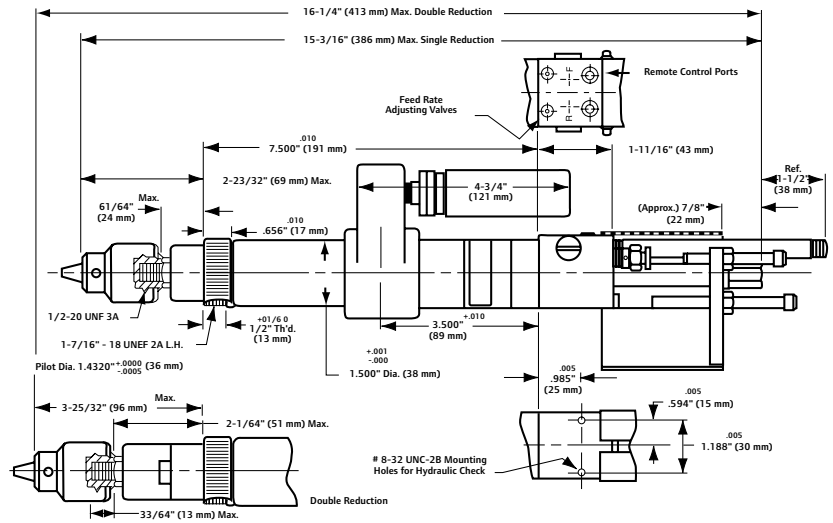

## Bant-A-Matic Drills 8245-B( )-2 And 8345-B( )-2

Tool Weight 4.8 lbs.

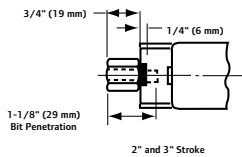

Shows built-in-collet used on 19,000 RPM Tools.

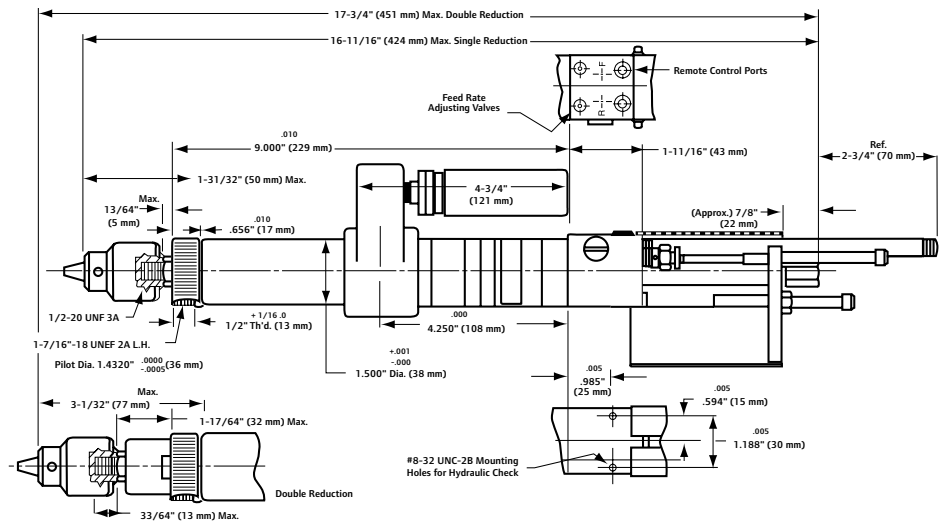

## Bant-A-Matic Drills 8245-B( )-3 And 8345-B( )-3

Tool Weight 5.8 lbs.

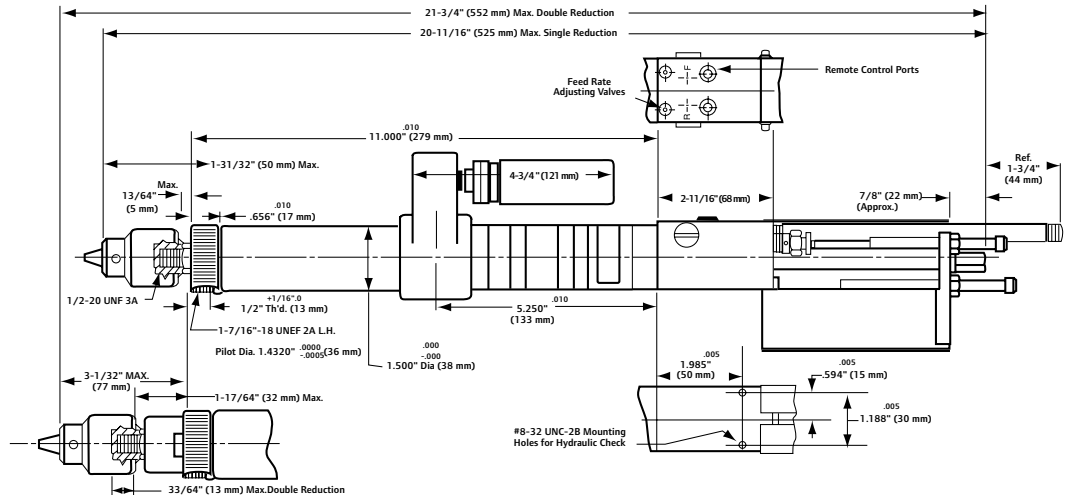
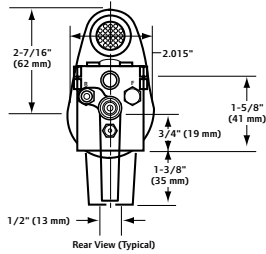

# Dimensional Data

## Bant-A-Matic Twin Drills 8248-B( )-1

Tool Weight 5.7 lbs.

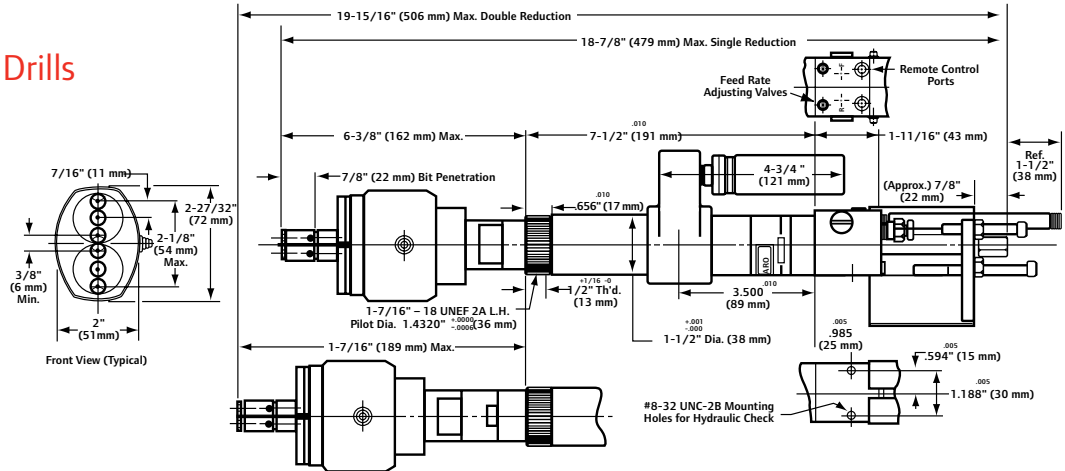

## Bant-A-Matic Twin Drills 8248-B( )-2

Tool Weight 6.3 lbs.

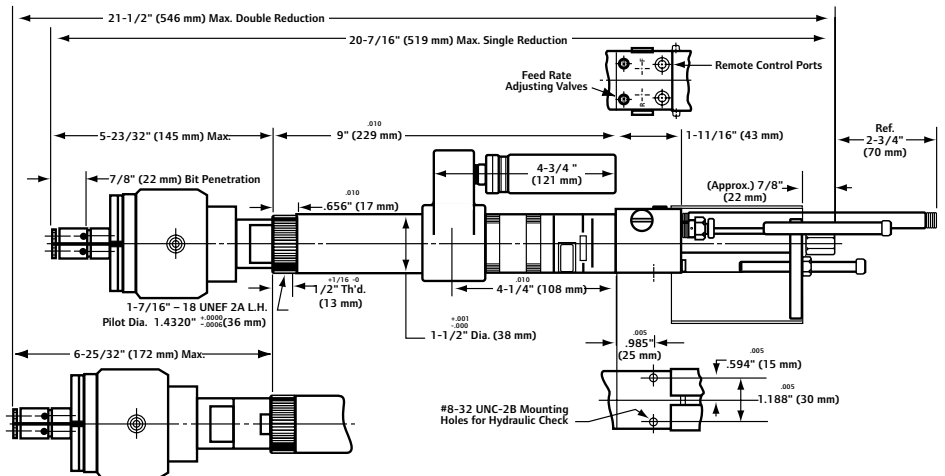

## Bant-A-Matic Twin Drills 8248-B( )-3

Tool Weight 7.3 lbs.

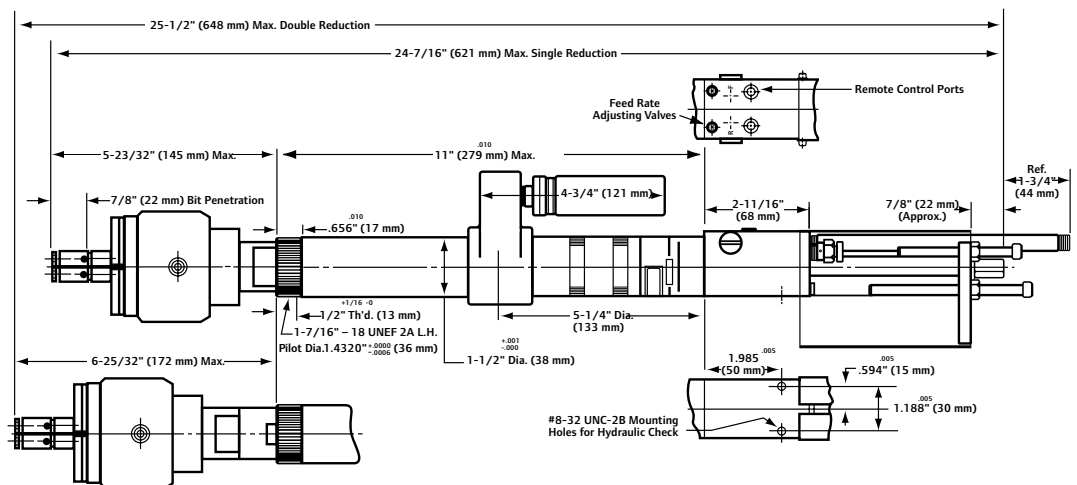



# Dimensional Data

## Par-A-Matic Drills 8255-A( )-1 And 8355-A( )-1

Shows built-in-collet used on 17,000 RPM Tools.

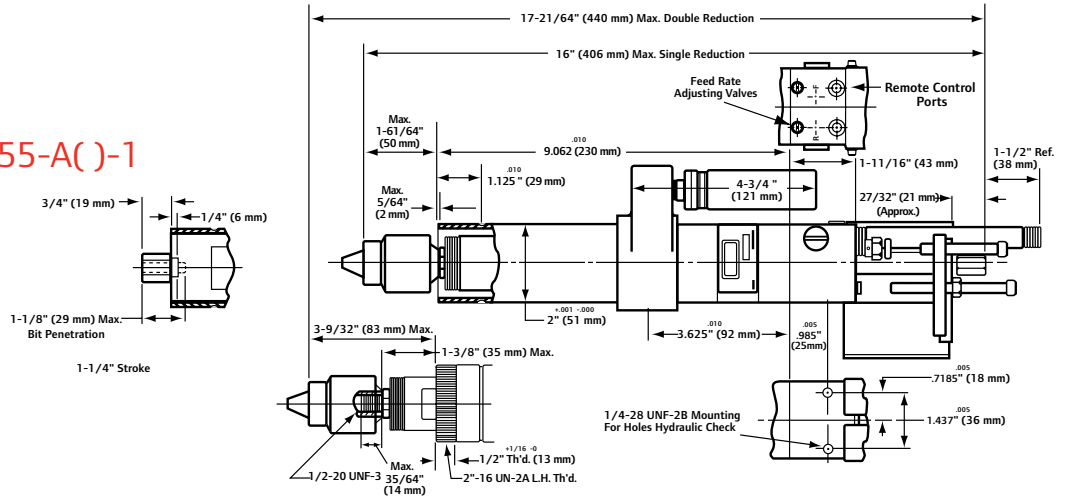

## Par-A-Matic Drills 8255-A( )-2 And 8355-A( )-2

Tool Weight 8.0 lbs.

Shows built-in-collet used on 19,000 RPM Tools.

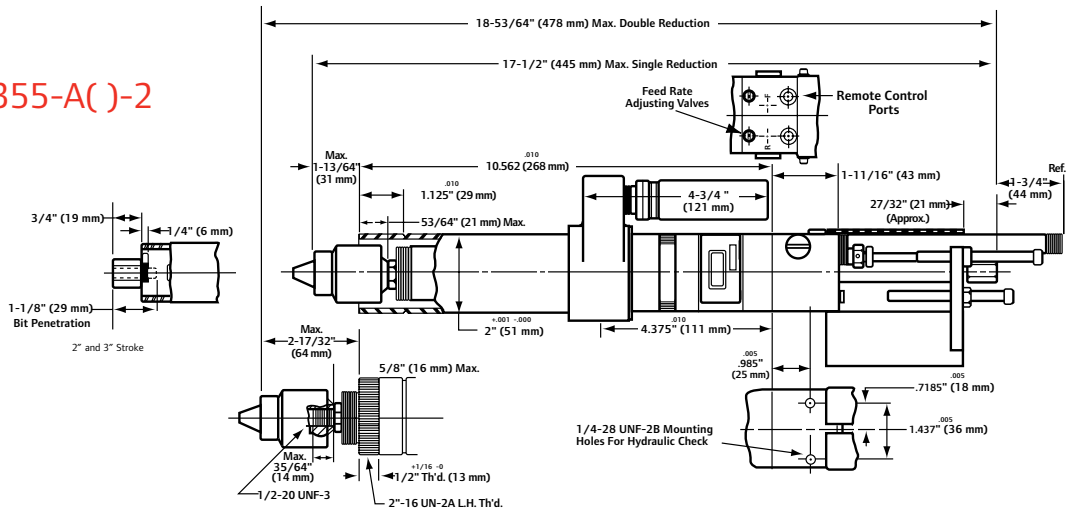

## Par-A-Matic Drills 8255-A( )-3 And 8355-A( )-3

Tool Weight 9.5 lbs.

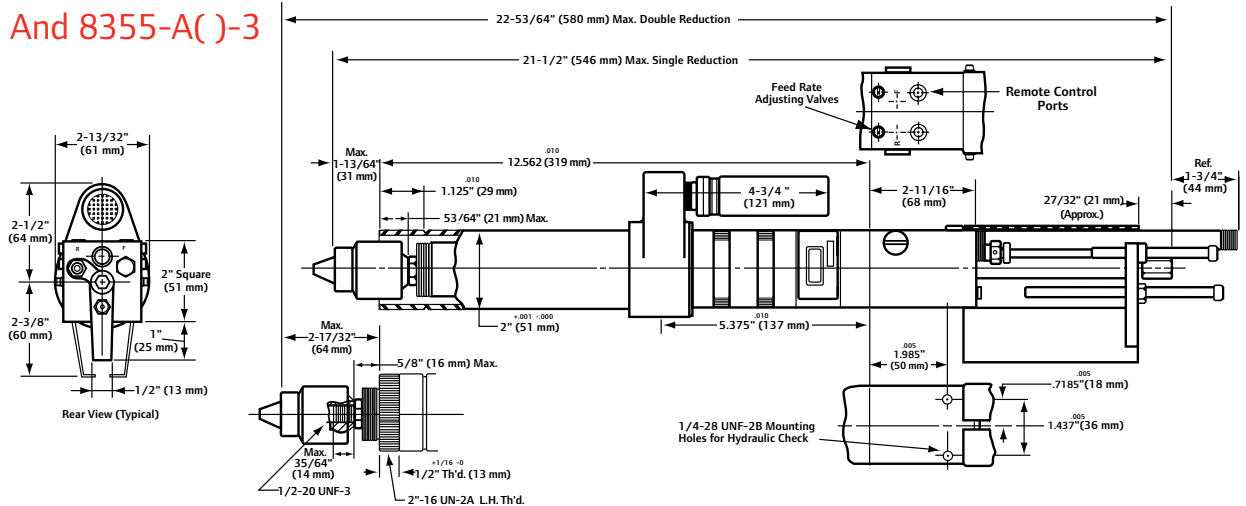

# Dimensional Data

## Par-A-Matic Twin Drills 8258-C(-)-1

Tool Weight 9.6 lbs.

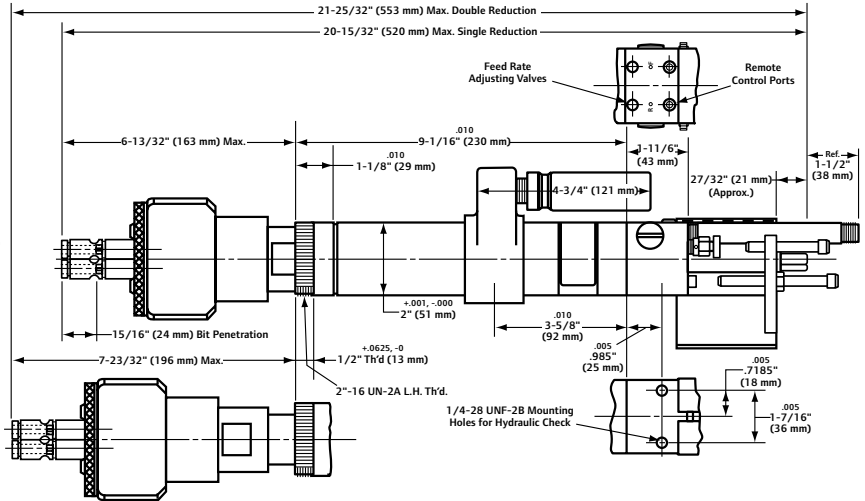
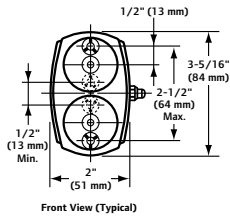

## Par-A-Matic Twin Drills 8258-C(-)-2

Tool Weight 10.1 lbs.

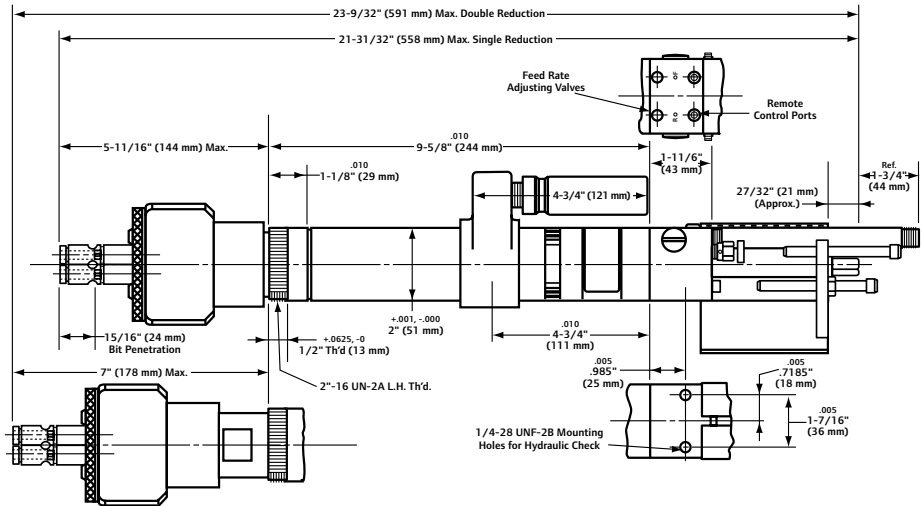

## Par-A-Matic Twin Drills 8258-C(-)-3

Tool Weight 11.6 lbs.

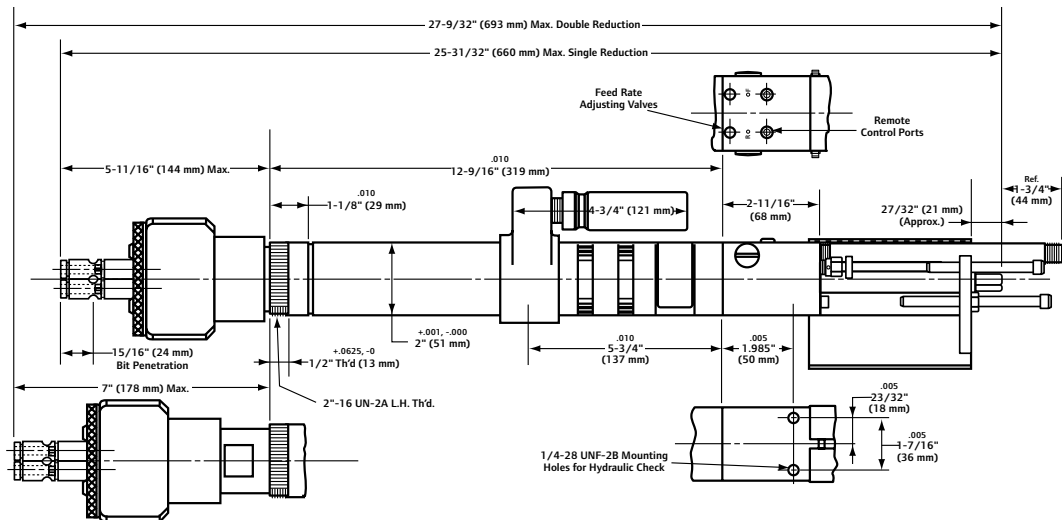

# Dimensional Data

## Super Par-A-Matic Drills 8265-( )-1

Tool Weight 13 lbs.

Shows built-in-collet used on 17,000 RPM Tools.

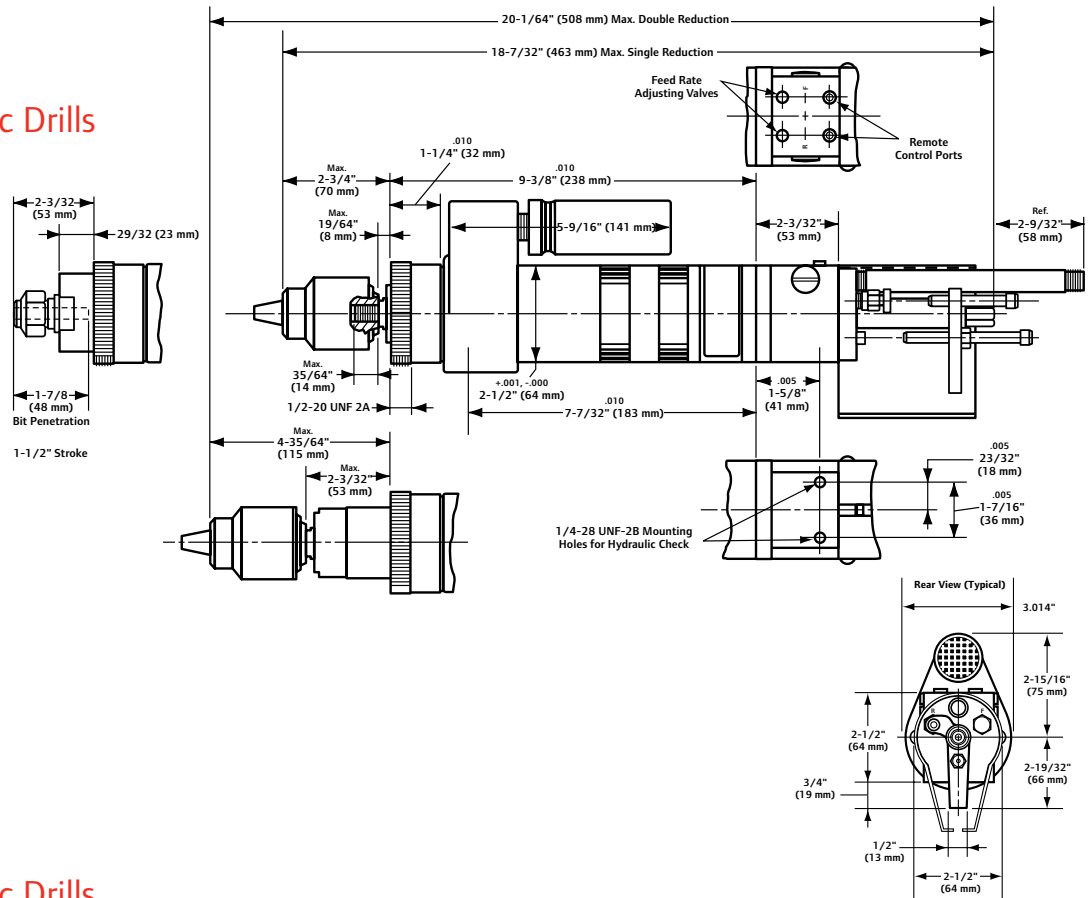

## Super Par-A-Matic Drills 8265-( )-3

Tool Weight 14 lbs.

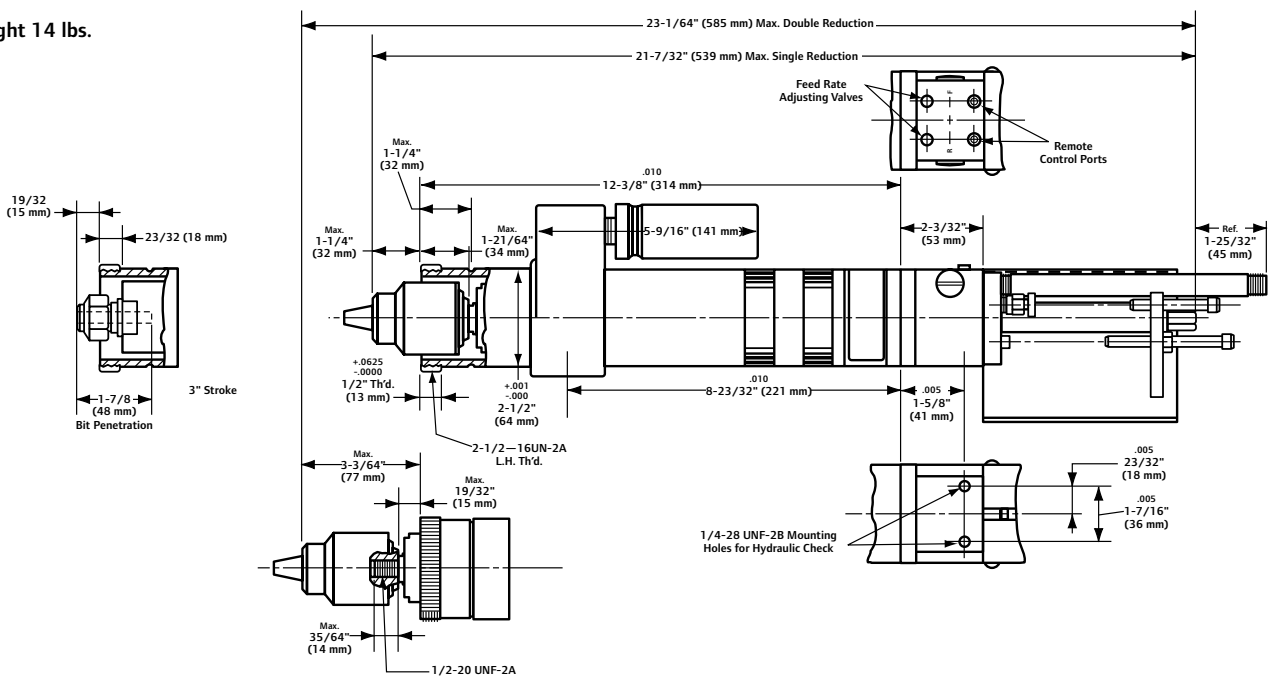

# Dimensional Data

## Super Par-A-Matic Twin Drills 8268-A( )-1

Tool Weight 18.5 lbs.

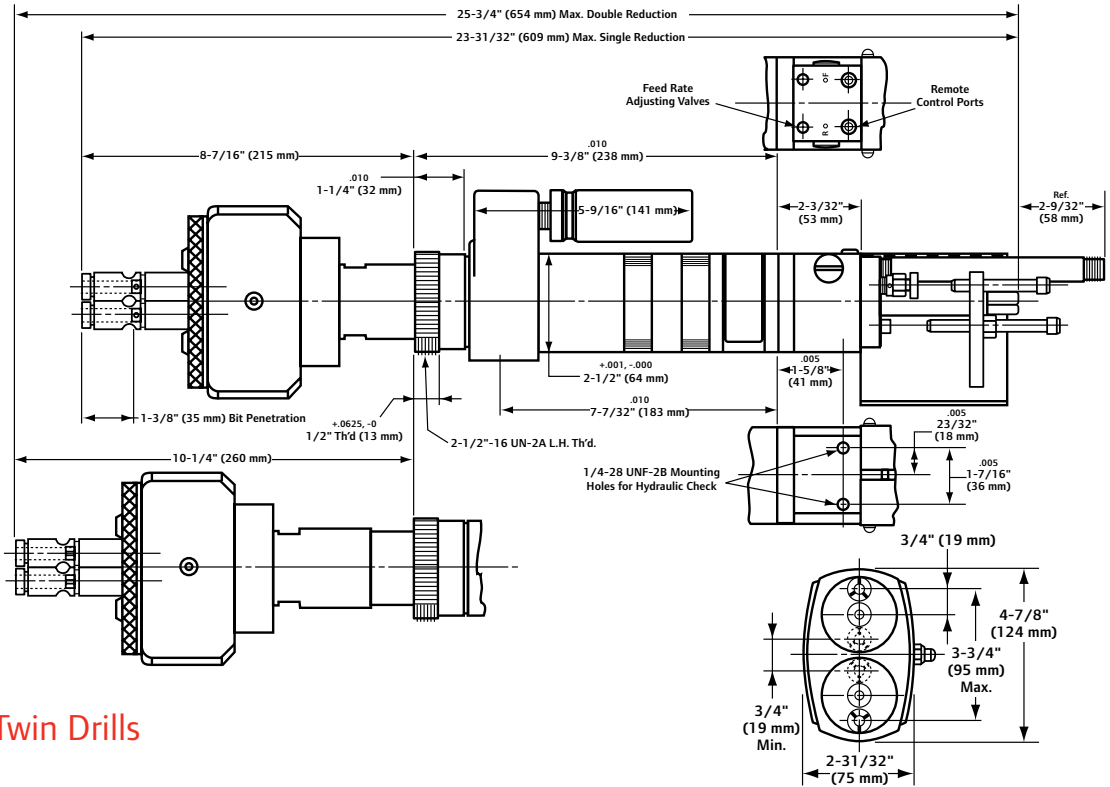

## Super Par-A-Matic Twin Drills 8268-A( )-3

Tool Weight 19.5 lbs.

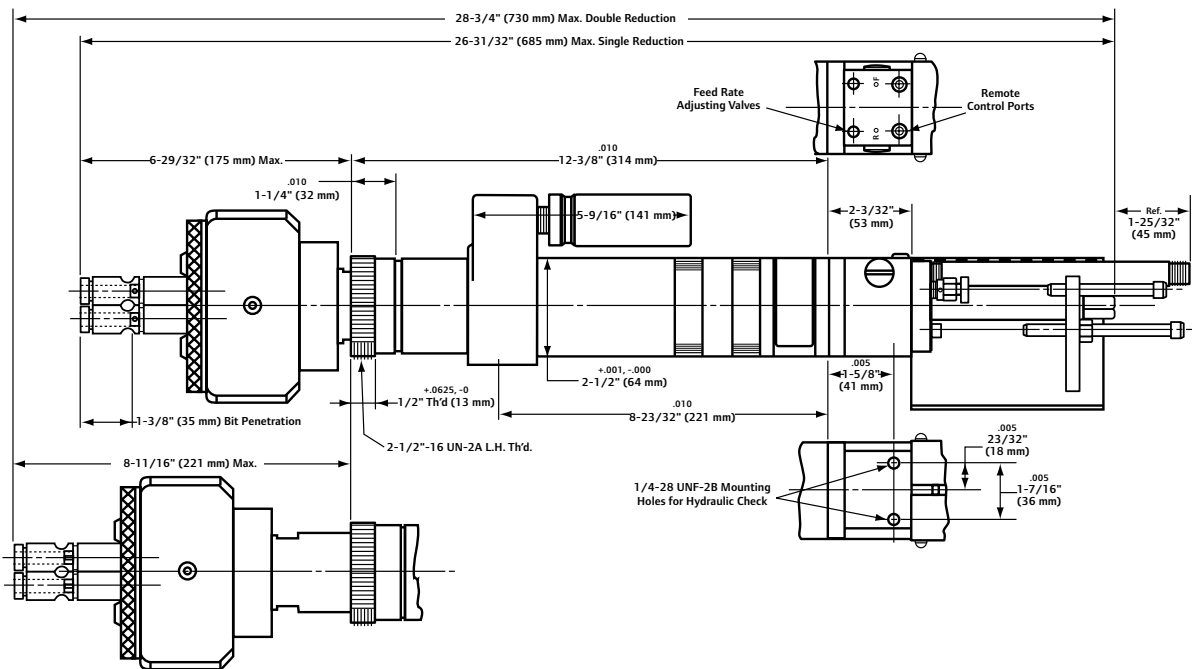

# Dimensional Data

## Hi-Thrust Drills 8670-( )-3

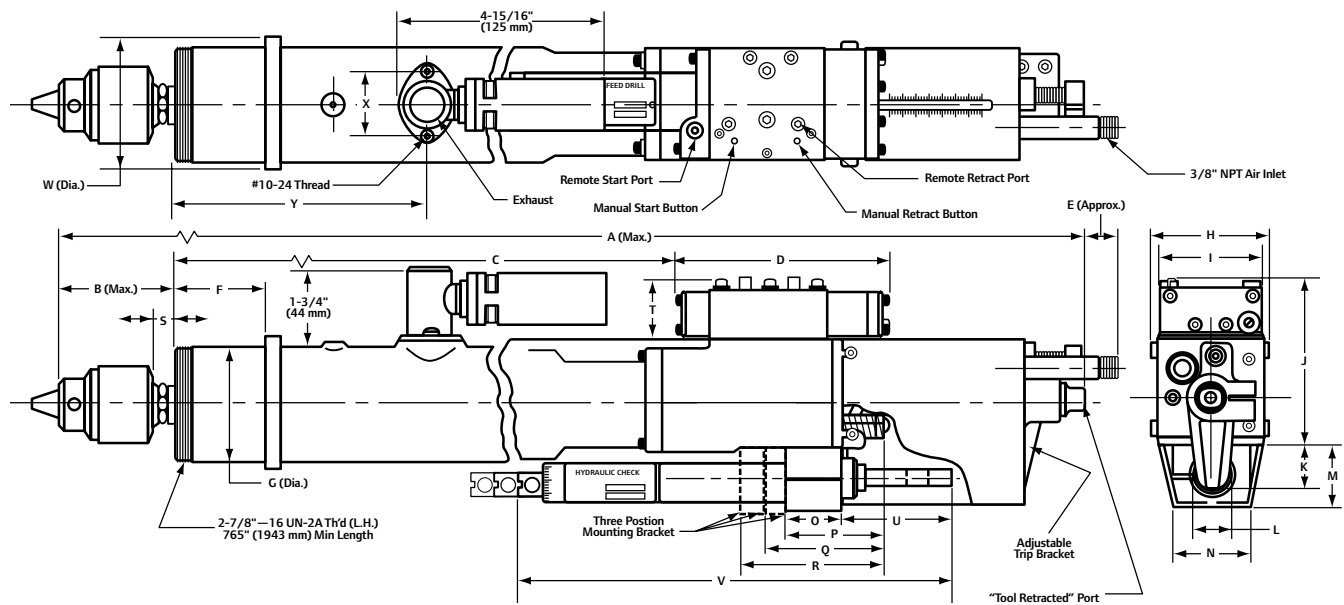

## 8670 - Specs

	A 3" Stroke	B	C	D	E 3" Stroke	F	G	H	I	J	K	L
in	27-3/4	3-21/32	14	5-5/16	1-1/16	2.24-2.26	2.872-2.874	2.784	2.5	4.312	61/64	.75
mm	705	93	355	135	27	56.9-57.4	72.95-73.0	70	64	110	24	19

	M	N	O	P	Q	R	S	T	HYDRAULIC CHECK						W	X	Y
									U			V					
									1" Stroke	2" Stroke	3" Stroke	1" Stroke	2" Stroke	3" Stroke			
in	1.5	2.0	1.25	2.375	2.937	3.5	15/32	1.5	1.937	2.937	3.937	7.875	10.875	13.875	3.25	1.562	6.344
mm	38	51	32	60	75	89	12	38	49	75	100	200	276	352	83	40	161

# Dimensional Data

## Par-A-Matic Offset Drills 8266-A( )-2

Tool Weight 8.6 Lbs.

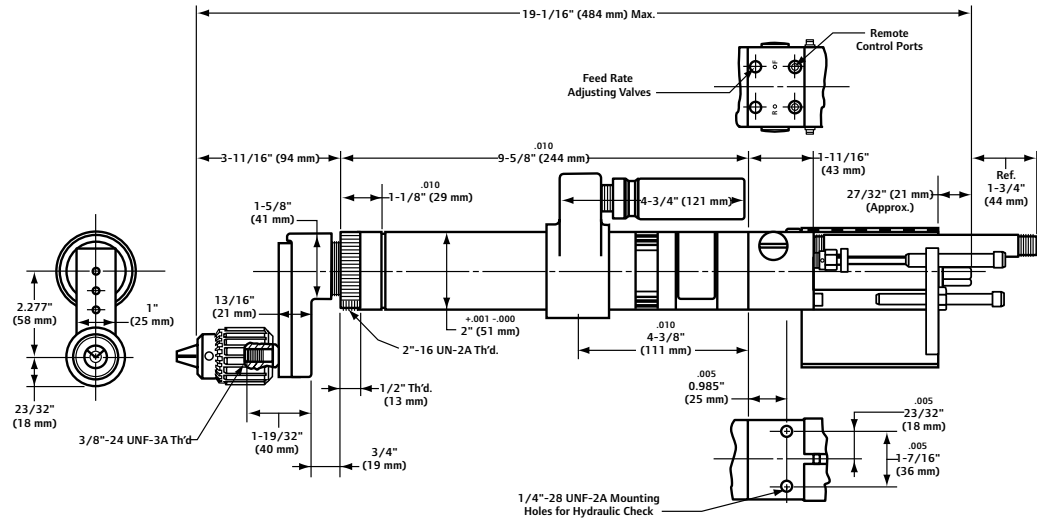

## Lead Screw Tappers 8655-B Thru 8659-B

Tool Weight 17 Lbs.

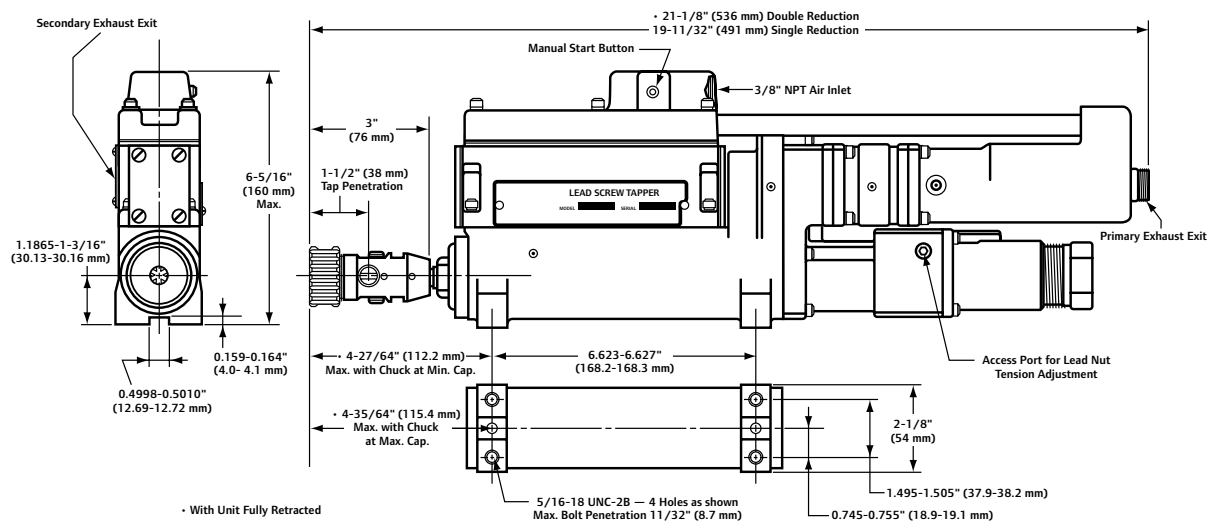

# Dimensional Data

## Bant-A-Matic Tappers 8246-D(-)-2

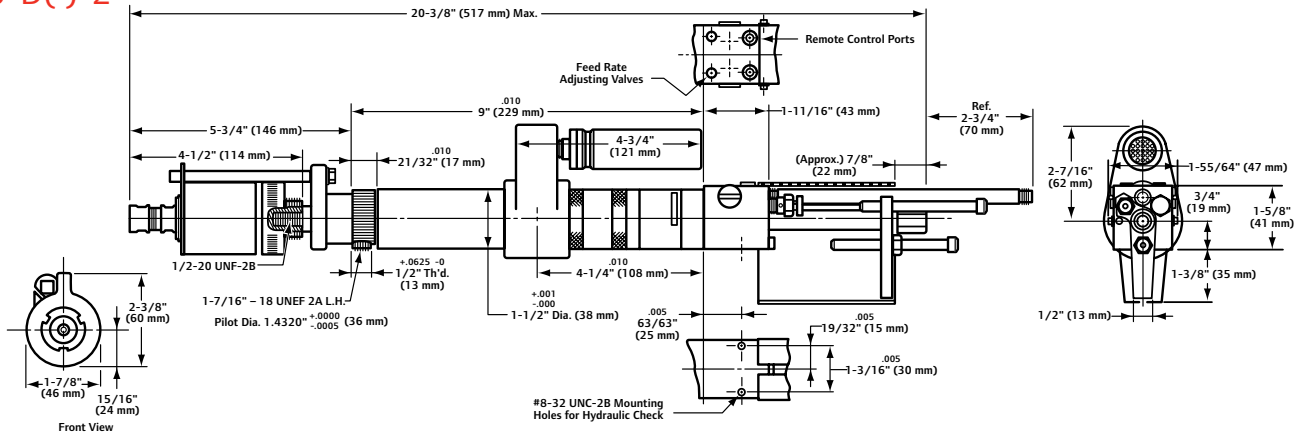

## Par-A-Matic Tappers 8256-C(-)-2

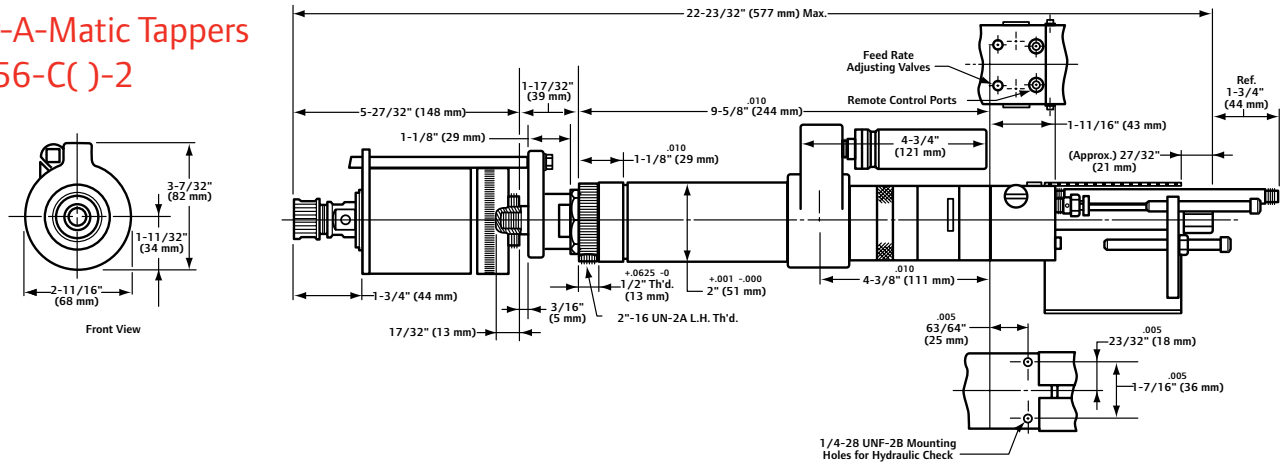

## Par-A-Matic Tappers 8257-A(-)-(-)

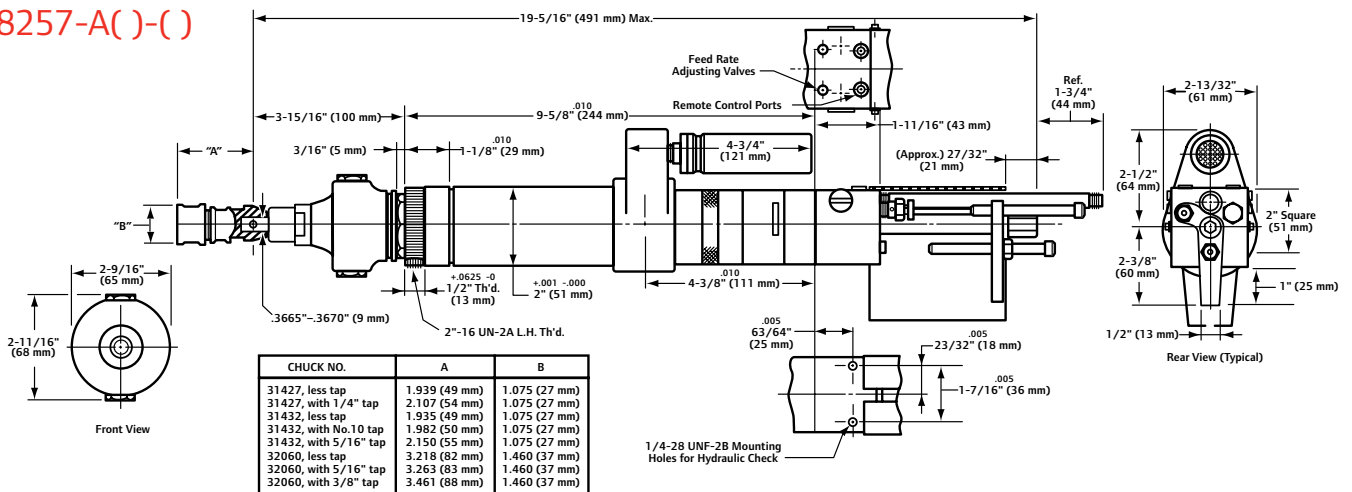

# Tappers

## Pistol Grip

### Q2 and 7 Series





Award-winning ergonomics coupled with proven durability and performance.

#### Features

- Ergonomically designed for operator comfort and high production rates
- Variable throttle for maximum control and minimum tap breakage
- Modular design makes servicing easy and economical
- Recommended for tapping applications up to 1/4" (Q2) and 1/2" (7)

#### Service and Accessories

##### Manuals:

 04577482	Q2 Series	 16572810	7 Series
 45587003		 16572273	
 45587011		 16572612	













##### Accessories (Q2 Series):

Torque reaction arm: QTA010  
Air tool oil: 10P  
Collet: 2U-103-1/4

##### Accessories (7 Series):

Torque reaction arm: QTA040  
Air tool oil: 10P  
Collet: 4U-103-1/2

Model	 Max Nm in-lbs (Nm)	 1 min. rpm	 lbs (kg)	 in (mm)	 in (mm)	 in (mm)	 cfm (L/Min)
<b>Q2 SERIES TRIGGER START</b>							
QP1S10D8D	3.8 (5.2)	1000	1.9 (0.9)	7.2" (183)	1/4" (6)	0.6" (15)	16 (450)
QP1S05D8D	7.2 (9.8)	500	1.9 (0.9)	7.2" (183)	1/4" (6)	0.6" (15)	16 (450)
<b>7 SERIES TRIGGER START</b>							
7RAQT4	19.9 (27)	475	3.3 (1.5)	11.8" (300)	1/2" (13)	0.9" (22)	27 (760)

Series			
Q2	75 dBa	1/4" NPT	1/4" (6 mm)
7	79 dBa	1/4" NPT	5/16" (8 mm)



# Tappers

## Pistol Grip

### 8500 and 7400 Series



Unique Quick Reverse Touch Control (QRT) trigger makes this design well-adapted to tapping applications.

#### 8500 Series Features

- Quick reverse trigger for fast light-duty tapping applications
- High- and low-speed model options
- Recommended for tapping applications up to 5/8"

#### Service and Accessories

##### Manuals:

	49999053	7400 Series
	49999032	8500 Series

#### Push-Pull Tapper

#### 7400 Series Features

- Designed for thread-chasing applications in metal fab shops after painting and cleanup operations
- Standard #10 to 5/16" capacity tapping chuck
- Available with 0 to 1/4" capacity (31427) and 5/16" to 5/8" capacity (32060) tapping chucks
- Recommended for tapping applications up to 5/8"

#### Accessories (8500 Series):

Torque reaction arm: QTA010  
Air tool oil: 10P  
Collet: 31437,31436,32061

#### Accessories (7400 Series):



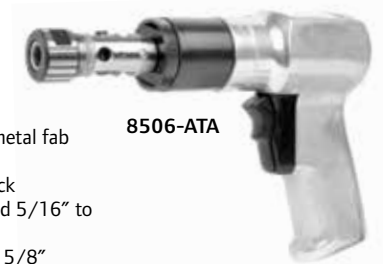



Torque reaction arm: QTA040  
Air tool oil: 10P  
Piped away exhaust kit: 44360-10







8506-ATA



7429-D

Model	 Max. Nm in-lbs (Nm)	 1 min. rpm	 lbs (kg)	 in (mm)	 in (mm)	 in (mm)	 cfm (L/Min)
<b>DC 8500 SERIES QTR TAPPERS</b>							
8506-ATA	9.2 (12.5)	600	2.7 (1.2)	8.2" (208)	No. 0 - 1/4"	0.9" (23)	24 (678)
8506-ATB	9.2 (12.5)	600	2.7" (1.2)	8.2" (208)	No. 10 - 5/16"	0.9" (23)	24 (678)
8506-ATC	9.2 (12.5)	600	2.7" (1.2)	8.2" (208)	5/16" - 5/8"	0.9" (23)	24 (678)
8509-ATA	6.7 (9.1)	900	2.7" (1.2)	8.2" (208)	No. 0 - 1/4"	0.9" (23)	26 (732)
8509-ATB	6.7 (9.1)	900	2.7" (1.2)	8.2" (208)	No. 10 - 5/16"	0.9" (23)	26 (732)
8509-ATC	6.7 (9.1)	900	2.7" (1.2)	8.2" (208)	5/16" - 5/8"	0.9" (23)	26 (732)
<b>DC 7400 SERIES PUSH-PULL TAPPERS</b>							
7429-D	19 (25.8)	550	3.9" (1.8)	12.0" (305.0)	5/16" (7.0)	1.3" (34)	27 (780)

Series				
8500	82 dBa	1/4" NPT	5/16" (8 mm)	1/2"-20
7400	85 dBa	1/4" NPT	5/16" (8 mm)	-

# Electrode Dressers

## Electrode Dressers

Economical solution to dressing worn electrode tips.

### Features

- Accurately dress electrodes from 5/16" to 1-1/2" diameter
- Lightweight and easy to operate
- Minimize downtime by quickly reconditioning tips on the machine
- Properly shaped electrode tips reduce energy consumption, extend electrode life, and maintain weld quality
- Lower speed models provide more dressing power at a slower material removal rate
- Recommended for reconditioning worn electrode tips



### Service and Accessories



#### Manuals:

 49999380

 49999483



Model	 rpm	Electrode Capacity Tip Diameter in (mm)	 lbs (kg)	 in (mm)
7165-B	1500	5/16" – 1 1/2" (7.9 – 38)	3.5 (1.6)	10-5/8" (270)
8040-E	1000	5/16" – 1 1/2" (7.9 – 38)	4.6 (2.1)	14-1/8" (359)
8039-E	450	5/16" – 1 1/2" (7.9 – 38)	5.5 (2.5)	14-1/8" (359)
8038-E	250	5/16" – 1 1/2" (7.9 – 38)	5.5 (2.5)	14 1/8" (359)

Type			
Dressers	83-88 dBa	1/4" NPT	5/16" (8 mm)

# Spindle Accessories

## Feed Drills

### Collet Selection For High Speed Drill Units

Collets, built into the spindle, are furnished as standard equipment on all highest speed feed tools. This provides for superior gripping, better balance and lower runout of smaller cutters typically used at these high speeds.

### For Bant-A-Matic And Par-A-Matic Tools

Models: 8245-203-( ), 8255-172-( ), 8360-172-3, 8345-203-( ) and 8355-172-( ).

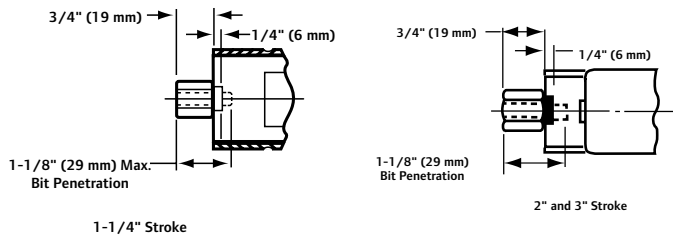

Order other available collet sizes shown above as, less 31812-8 with 31812-( ).

Collet Insert No.	Normal Size	Min. Cap. in (mm)	Max. Cap. in (mm)
31812-1	3/64	1/64 (0.40)	3/64 (1.19)
31812-2	5/64	3/64 (1.19)	5/64 (1.98)
31812-3	3/32	1/16 (1.59)	3/32 (2.38)
31812-4	1/8	3/32 (2.38)	1/8 (3.18)
31812-5	5/32	1/8 (3.18)	5/32 (3.97)
31812-6	3/16	5/32 (3.97)	3/16 (4.76)
31812-7	7/32	3/16 (4.76)	7.32 (5.56)
<b>31812-8*</b>	<b>1/4</b>	<b>7/32 (5.56)</b>	<b>5.56 (6.35)</b>

\*Standard equipment

### For Super Par-A-Matic Tools

Models: 8265-171-( ).

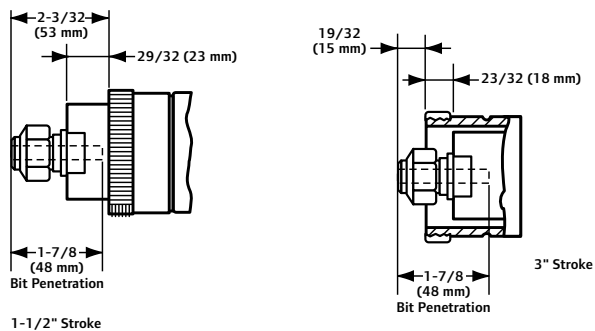

Order other available collet sizes shown above as, less 32968-9 with 32968-( ).

Collet Insert No.	Normal Size	Min. Cap. in (mm)	Max. Cap. in (mm)
32968-1	1/8	1/64 (0.40)	3/64 (1.19)
32968-2	5/32	3/64 (1.19)	5/64 (1.98)
32968-3	3/16	1/16 (1.59)	3/32 (2.38)
32968-4	7/32	3/32 (2.38)	1/8 (3.18)
32968-5	1/4	1/8 (3.18)	5/32 (3.97)
32968-6	9/32	5/32 (3.97)	3/16 (4.76)
32968-7	5/16	3/16 (4.76)	7.32 (5.56)
32968-8	11/32	7/32 (5.56)	1/4 (6.35)
<b>32968-9*</b>	<b>3/8</b>	<b>11/32 (8.73)</b>	<b>8.73 (9.53)</b>

\*Standard equipment

# Spindle Accessories

## Drill Adapters

Part Number	Thread Size	Drive
<b>SQUARE DRIVE ADAPTER</b>		
R0H-P212-3/8	3/8" -24 female thread	3/8"
<b>QUICK CHANGE ADAPTER</b>		
R0H-A925-4	3/8" - 24	1/4"
Part Number	Thread Size	Drive
<b>SPINDLE ADAPTERS</b>		
30629	1/2"-20 (male)	3/8"-24
30384-5	3/8" square	3/8"-24
30384-9	1/2" square	3/8"-24
40768	1/2" square	1/2"-20



## General Chucks

Part Number	Chuck Size	Thread Size	Key
<b>DRILL CHUCKS</b>			
7802-99	3/8"	3/8" - 24	N/A
30016	3/8"	1/2" - 20	N/A
7803-99	1/2"	3/8" - 24	R1T-J253
R1N-99A	1/2"	1/2" - 20	N/
36953	1/4"	No. 1 taper	N/A
33906	1/4"	1/2" - 20	N/A
<b>KEYLESS CHUCKS</b>			
728-99-KC5	3/8"	3/8" - 24	N/A
728-99-KC8	1/2"	3/8" - 24	N/A
<b>STANDARD DUTY CHUCKS</b>			
7801-99-6	3/8"	3/8" - 24	728N-253
7806-99-8	1/2"	3/8" - 24	728N-253
<b>MEDIUM DUTY CHUCKS</b>			
R0H-99	1/4"	3/8" - 24	R1H-J253
<b>HEAVY DUTY CHUCKS</b>			
6A-99	3/8"	3/8" - 24	R0J-J253
R00A-99	1/4"	3/8" - 24	R00A-J253
R0K-99	5/64" - 1/2"	3/8" - 24	R1T-J253



## Power Quick Change Chucks

Part Number	Square Drive Female	Hex Chuck Size Female
2U-A925-4	3/8"	1/4"
502-A925-7	3/8"	7/16"
4U-A925-7	1/2"	7/16"

## Other Accessories

### Ergo Grips / Bio Grips / Comfort Grips

Part Number	Used With:
<b>ERGO GRIPS</b>	
SEG3A-IR	Series 1
SEG4-IR	Series 41 (1700 rpm or less)
SEG4H-IR	Series 41 (over 1700 rpm)
<b>REPLACEMENT FOAM GRIP KITS</b>	
SEG3A-CGK	For SEG3 models
SEG4-CGK	For SEG4 models
<b>BIO BRACE</b>	
SBB4-AR41	Series 41 (1700 rpm or less)
SBB4-QE2	QE2
SBB4-VS	VersaTec
<b>COMFORT GRIPS</b>	
CG-6X8	6" x 8" sheet with tape

### Lubricants

Part Number	Used With:
<b>CLASS 1 #10 OILS FOR AIR TOOLS</b>	
10Z4	4 oz oil
10P	1 pt oil
10G	1 gal oil
10G55	55 gal oil
<b>GREASE</b>	
23-1 LB	#23 - 1 lb - drill gearing
28 1 LB	#28 - 1 lb - SD gearing and clutches
28 8 LB	#28 - 8 lb - SD gearing and clutches
66 1 LB	#66 - 1 lb - slow-speed angle heads
66 8 LB	#66 - 8 lb - slow-speed angle heads
67-4T	#67 - 4 oz tube - high-speed angle heads
GTH-1	grease gun for 4 oz tube
67-1 LB	#67 - 1 lb - high-speed angle heads
67 8 LB	#67 - 8 lb - high-speed angle heads
68-1LB	#68 - 1 lb - Coupling splines

### 360° Swivel Air Inlets

Part Number	Inlet	CFM	Type
ASA-1/4	0-25	1/4"	Adjustable
ASC-1/4	0-33	1/4"	Non-marring
AS-3/8	0-45	3/8"	Standard
AS-1/2	0-65	1/2"	Standard

### Angle Head Boots

25 mm	28 mm	35 mm	43 mm	48 mm	56 mm
131996	131995	131997	GEA40-172	GEA40-173	GEA240-173

Based on tool angle head diameter



### Polyurethane Coil Hoses

Part Number	Description
P14-10	1/4" x 10' polyurethane coil hose, (1) 1/4" rigid, (1) 1/4" swivel fitting
P14-20	1/4" x 20' polyurethane coil hose, (1) 1/4" rigid, (1) 1/4" swivel fitting
P14-30	1/4" x 30' polyurethane coil hose, (1) 1/4" rigid, (1) 1/4" swivel fitting
P38-10	3/8" x 10' polyurethane coil hose, (1) 3/8" rigid, (1) 3/8" swivel fitting
P38-20	3/8" x 20' polyurethane coil hose, (1) 3/8" rigid, (1) 3/8" swivel fitting
P38-30	3/8" x 30' polyurethane coil hose, (1) 3/8" rigid, (1) 3/8" swivel fitting
P12-10R	1/2" x 10' polyurethane coil hose, (2) 1/2" reusable swivel fittings
P12-20R	1/2" x 20' polyurethane coil hose, (2) 1/2" reusable swivel fittings
P12-30R	1/2" x 30' polyurethane coil hose, (2) 1/2" reusable swivel fittings

# Drilling Guide

## Selection Chart

Suggested surface speeds for high-speed steel drills in various materials.

Material	Speed in SFM
Alloy steel (300 to 400 Brinell)	20 to 30
Stainless steel	30 to 40
Automotive steel forgings	40 to 50
Tool steel, 1.2C	50 to 60
Steel, .4C to .5C	70 to 80
Mild machinery, .2C to .3C	80 to 110
Hard-chilled cast iron	30 to 40
Medium-hard cast iron	70 to 100
Soft cast iron	100 to 150

Material	Speed in SFM
Malleable iron	80 to 90
Monel metal	40 to 50
High tensile-strength bronze	70 to 150
Ordinary brass and bronze	200 to 300
Aluminum and its alloys	200 to 300
Magnesium and its alloys	250 to 400
Slate, marble and stone	15 to 25
Bakelite and similar material	100 to 150
Wood	300 to 400

Note: Carbon-steel twist drills should be run at speeds of 40 to 50 percent of those given above.

## Drilling Speed (rpm) = 0.75 x Free Speed (rpm)

Hole Diameter In	Surface Speed, Feet Per Minute												
	30	40	50	60	70	80	90	100	110	150	200	300	400
<b>DRILLING SPEED, RPM (OPTIMUM OPERATING SPEED - NOT CATALOGED FREE SPEED)</b>													
1/16"	1800	2400	3000	3600	4200	4900	5500	6100	6700	9000	12,000	18,000	24,000
1/8"	900	1200	1500	1800	2100	2400	2700	3000	3400	4600	6100	9200	12,000
3/16"	600	800	1000	1200	1400	1600	1800	2000	2200	3100	4100	6100	8100
1/4"	450	600	750	900	1100	1200	1400	1500	1700	2300	3100	4600	6100
5/16"	350	500	600	750	850	1000	1100	1200	1300	1800	2400	3700	4900
3/8"	300	400	500	600	700	800	900	1000	1100	1500	2000	3000	4000
1/2"	200	300	400	450	550	600	650	750	850	1100	1500	2300	3000

# Service Kits

## Feed Drills

Service kits are a convenient and economical way to perform in-house preventative maintenance and minimize tool repair downtime. Service Kits are available for nearly all model automatic machining tools. Each kit contains all of the replacement parts needed to properly perform preventative maintenance on a tool to keep it operating “like new”. They also serve as an easy method to manage and organize spare parts inventory.

Each part in the service kit is individually wrapped and identified, and packaged in an easy-to-store clearly labeled box. The appropriate tool service manual, parts list, spindle oil and grease are also included.

## Bant-A-Matic Series

Models	Description	Kit Number
8245-B8, 8245-B45 & 8245-202	Drills	
8246-D8	Tapper	
8345-B8, 8345-B45 & 8345-202	Drills	41 205-1
8248-B8 & 8248-B45	Twin Drills	
8245-B30 & 8245-101	Drills	
8246-D5	Tapper	
8345-B30 & 8345-101	Drills	41 310-1
8248-B30	Twin Drill	



## Par-A-Matic Series

Models	Description	Kit Number
All 8255-A	Drills	
All 8256-C	Tappers	
All 8257-A	Tappers	
All 8258-C	Twin Drills	
All 8266-A	Offset Drills	41 325
All 8355-A	Drills	
All 8360-A	Peck Drills	

## Hi-Thrust Series

Models	Description	Kit Number
All 8660	Drills	45831
All 8670	Drills	45832

## Super Par-A-Matic Series

Models	Description	Kit Number
All 8265	Drills	
All 8268-A	Twin Drills	41327

## Lead Screw Tappers

Models	Description	Kit Number
All 8655-B	Tappers	
All 8656-B	Tappers	
All 8657-B	Tappers	45782
All 8658-B	Tappers	
All 8659-B	Tappers	41325



Ingersoll Rand (NYSE:IR) advances the quality of life by creating comfortable, sustainable and efficient environments. Our people and our family of brands—including Club Car®, Ingersoll Rand®, Thermo King® and Trane®—work together to enhance the quality and comfort of air in homes and buildings; transport and protect food and perishables; and increase industrial productivity and efficiency. We are a \$12 billion global business committed to a world of sustainable progress and enduring results.



[www.ingersollrandproducts.com](http://www.ingersollrandproducts.com)

Distributed by:

Ingersoll Rand, IR and the IR logo are trademarks of Ingersoll Rand, its subsidiaries and/or affiliates. All other trademarks are the property of their respective owners. Nothing contained on these pages is intended to extend any warranty or representation, expressed or implied, regarding the product described herein. Any such warranties or other terms and conditions of sale of products shall be in accordance with Ingersoll Rand's standard terms and conditions of sale for such products, which are available upon request.

Product improvement is a continuing goal at Ingersoll Rand. Designs and specifications are subject to change without notice or obligation.